

ibaLink-VME

VMEbus Interface Board

Manual

Issue 2.0

Manufacturer

iba AG
Koenigswarterstr. 44
90762 Fuerth
Germany

Contacts

Head office +49 911 97282-0
Fax +49 911 97282-33
Support +49 911 97282-14
Technology +49 911 97282-13

E-Mail: iba@iba-ag.com

Web: www.iba-ag.com

This manual must not be circulated or copied, or its contents utilized and disseminated, without our express written permission. Any breach or infringement of this provision will result in liability for damages.

©iba AG 2023, All Rights Reserved

The content of this publication has been checked for compliance with the described hardware and software. Nevertheless, deviations cannot be excluded completely so that the full compliance is not guaranteed. However, the information in this publication is updated regularly. Required corrections are contained in the following regulations or can be downloaded on the Internet.

The current version is available for download on our web site <http://www.iba-ag.com>.

Protection note

Windows® is a label and registered trademark of the Microsoft Corporation. Other product and company names mentioned in this manual can be labels or registered trademarks of the corresponding owners.

Certification

The device is certified according to the European standards and directives. This device corresponds to the general safety and health requirements. Further international customary standards and directives have been observed.



Issue	Date	Revision	Chapter	Author	Version HW / FW
1.10	01-2023	Added S1 - Mode 5 extension ibaPDA screenshots updated		cv	FW V02.03.001

Table of contents

1	About this manual	5
1.1	Target group	5
1.2	Notations	5
1.3	Used symbols	6
2	Introduction	7
3	Scope of delivery	9
4	Safety instructions	9
4.1	Designated use.....	9
4.2	Special advices.....	9
5	System requirements	10
5.1	Hardware	10
5.2	Software	10
5.3	PLC or control system	10
6	Installation / Deinstallation	11
6.1	Installing the card.....	11
6.2	Removing the card.....	12
7	Device description	13
7.1	Connectors and Operational Elements on Front Panel	13
7.1.1	Fiber optic connections.....	13
7.1.2	Rotary switches	14
7.1.3	Status LEDs.....	15
7.2	Operation modes	16
7.2.1	ibaNet 3Mbit (mode 0)	16
7.2.2	ibaNet 3Mbit with diagnostics (mode 1)	17
7.2.3	ibaNet 3Mbit P2P (mode 8).....	18
7.2.4	ibaNet 3Mbit P2P with diagnostics (mode 9).....	18
7.2.5	ibaNet 32Mbit P2P (mode 4).....	19
7.2.6	ibaNet mixed mode - 32Mbit P2P transmit and 3Mbit receive (mode 5)	20
7.2.7	32Mbit Flex (mode F).....	22
7.3	DIP Switches on Board.....	23
7.3.1	Function of DIP Switches.....	24
7.3.2	Setting the VMEbus Start Address.....	26
8	Settings for Host systems	27
8.1	Settings for ALSPA CP80/A800 (AEG Logidyn D).....	27
8.1.1	Card Settings.....	28
8.1.2	Switch Settings on Front Panel of ibaLink-VME	28
8.2	Settings for ALSPA C80 HPC (Logidyn D2).....	29
8.2.1	Engineering notes for ibaLink-VME with ALSPA C80 HPC (Logidyn D2).....	29
8.2.2	Card Settings.....	29
8.2.3	Use of the ibaLink-VME in SM128 compatibility mode	30
8.2.4	Use of the ibaLink-VME in 32Mbit P2P mode	32
8.3	Settings for HPCi	37

8.3.1	Engineering notes	37
8.3.2	Card Settings	37
8.3.3	Use of the ibaLink-VME in SM128 compatibility mode.....	38
8.3.4	Use of the ibaLink-VME in 32Mbit P2P mode or 32Mbit Flex mode	39
8.3.5	Use of the ibaLink-VME in mixed mode: 32Mbit P2P transmit and 3Mbit receive	40
8.4	Settings for GE 90/70	42
8.4.1	Card settings	42
8.4.2	Switch Settings on Front Panel of ibaLink-VME	42
8.5	Settings for SIMATIC TDC.....	43
8.5.1	Engineering notes for Simatic TDC.....	43
8.5.2	Card settings	45
8.5.3	Switch Settings on Front Panel of ibaLink-VME	45
9	System Topologies	46
9.1	ibaPDA Application	46
9.1.1	Configuration in 3Mbit mode.....	46
9.1.2	Configuration in 32Mbit P2P mode (4) and mixed mode (5).....	47
9.1.3	Configuration in 32Mbit Flex mode	50
9.2	ibaLogic Application.....	56
9.2.1	ibaLogic V3 Configuration	56
9.2.2	ibaLogic V4 Configuration	57
9.3	Cascade with 3Mbit mode	59
9.4	Cascade with 32Mbit Flex	61
9.5	Process I/O Mode.....	62
10	The VMEbus interface	63
10.1	Address mapping	63
10.2	Global overview.....	64
10.3	Control/Status/Version registers	65
10.4	SM128 RX/TX	66
10.5	4K RX/TX buffers	67
10.5.1	32Mbit P2P.....	67
10.5.2	32Mbit Flex.....	67
11	Technical Data.....	68
11.1	Main data	68
11.2	Dimension sheet.....	69
11.3	Example for FO budget calculation.....	70
12	Support and contact.....	72

1 About this manual

This compact manual provides the information for installation and handling of the VME interface board ibaLink-VME.

For further information concerning the system integration and software configuration please refer to the corresponding engineering manuals and / or software documentation of our software products used in conjunction with this device.

1.1 Target group

This manual addresses in particular the qualified professionals who are familiar with handling electrical and electronic modules as well as communication and measurement technology. A person is regarded to as professional if he/she is capable of assessing safety and recognizing possible consequences and risks on the basis of his/her specialist training, knowledge and experience and knowledge of the standard regulations.

1.2 Notations

The following designations are used in this manual:

Action	Notations
Menu command	Menu <i>Logic diagram</i>
Call of menu command	<i>Step 1 – Step 2 – Step 3 – Step x</i> Example: Select menu <i>Logic diagram – Add – New logic diagram</i>
Keys	<Key name> Example: <Alt>; <F1>
Press keys simultaneously	<Key name> + <Key name> Example: <Alt> + <Ctrl>
Buttons	<Button name> Example: <OK>; <Cancel>
File names, Paths	„File name“, „Path“ Example: „Test.doc“

1.3 Used symbols

If safety instructions or other notes are used in this manual, they mean:



DANGER

The non-observance of this safety information may result in an imminent risk of death or severe injury:

- By an electric shock!
- Due to the improper handling of software products which are coupled to input and output procedures with control function!

If you do not observe the safety instructions regarding the process and the system or machine to be controlled, there is a risk of death or severe injury!



WARNING

The non-observance of this safety information may result in a potential risk of death or severe injury!



CAUTION

The non-observance of this safety information may result in a potential risk of injury or material damage!



Note

A note specifies special requirements or actions to be observed.



Tip

Tip or example as a helpful note or insider tip to make the work a little bit easier.



Other documentation

Reference to additional documentation or further reading.

2 Introduction

The ibaLink-VME interface card is a multi-purpose, bidirectional interface card designed for use in VMEbus compatible PLCs and computer systems. It may be used for data acquisition and process monitoring purposes as well as in control system applications, such as the ibaLogic SoftPLC.

ibaLink-VME is the successor of the ibaLink-SM-128V-i-2o card (also called here SM128) and completely compatible with the previous functions in 3Mbit mode. In addition ibaLink-VME offers new functions using the ibaNet protocols 32Mbit and 32Mbit Flex.

Key features of the card include:

- ❑ 1 bidirectional fiber-optic link for inputs/outputs (channel 1)
- ❑ 1 unidirectional fiber-optic link for outputs (channel 2)
- ❑ ibaNet protocols 3Mbit, 32Mbit and 32Mbit Flex
- ❑ Flexible data selection and rate setting with 32Mbit Flex
- ❑ Cascading of up to 15 devices in 32Mbit Flex mode at channel 1
- ❑ Compatible interface for all ibaFOB cards
- ❑ Compatible process i/o interface for ibaPADU-8-IO series and ibaNet750-BM series
- ❑ Block coherent mode
- ❑ Data exchange between 2 systems in Peer-to-Peer mode (P2P)

The ibaLink-VME can be used in both VME32 and VME64 systems (6U height). 5 V power supply is required (from VMEbus).

VME specification according to ANSI VITA 1-1994:

- ❑ Supported addressing modes: **A24, A32, A40, A64**
- ❑ Supported data transfers: 8/16/32 bit (**D08/D16/D32/MD32**)
- ❑ 8/16/32 bit block transfer modes are supported (**BLT**)
- ❑ 64 bit block transfer mode is supported (**MBLT**)
- ❑ Support for unaligned transfers (**UAT**) and read-modify-write (**RMW**)

The following modes are not supported:

- Auto configuration (AutoSlotID)
- 2eVME/2eSST

The ibaLink-VME is a passive slave board on the VMEbus, i.e. no active master access on the VMEbus will be performed. The board occupies a 256 kByte address space on the VMEbus.

Coherent mode

The exchange of VME and fiber optic data happens asynchronously from each other. This means that blocks of data that are written on the VME side are not necessarily transported over the fiber optic telegram as one block. There is only some coherence guaranteed based on the type of write access that was used (byte, word or dword).

When coherent transmission of a complete block of data is needed, a special 'Coherent Mode' could be enabled by setting a DIP switch. Now the VME receive and transmit buffers are only updated when the user writes to a special Update Register. In this way it is possible to keep blocks of coherent data together.

Fields of application

3Mbit protocol

When using the 3Mbit ibaNet protocol, all iba devices supporting this protocol can be connected to the input and output. The following applications are possible:

- Computer coupling to SIMATIC S5, SIMIKRO MMC and SIMADYN D (ibaLink-SM-64-io and -SD-16)
 - Input and output of peripheral signals (e.g. ibaPADU-8, -16, -32, -8-O, ibaNet750-BM)
 - Coupling to ibaLogic-V3, ibaLogic-V4, ibaPDA (all ibaFOB cards), can also be cascaded with ibaPADU and ibaNet750
 - Bidirectional coupling to a Profibus master, e.g. SIMATIC S7 (ibaBM-DPM-S-64)
 - Multiplying output signals (ibaBM-FOX-i-3o(-D))
- see description chapter 7.2.1

32Mbit P2P protocol

Using the fast P2P protocol the following connections are possible, depending on the telegram type:

- Fast computer coupling (up to 50µs) between VMEbus based automation systems, e.g. SIMATIC TDC, HPCi, LOGIDYN D (ibaLink-VME)
 - Fast computer coupling to ibaLogic-V4 (iba-FOB-xx-D and ibaFOB-io-ExpressCard)
 - Computer coupling to systems with embedded iba-FPGA, e.g. ABB AC800 PEC
 - Fast connection to I/O peripheral devices, e.g. ibaPADU-S-IT with ibaLogic
 - Connection to SINAMICS LINK (ibaBM-SiLink)
 - Connection to a collector and distributor (ibaBM-COL-8i-o and ibaBM-DIS-i-8o)
- see description chapter 7.2.5

32Mbit Flex protocol

Using 32Mbit Flex protocol ibaLink-VME is compatible to all 32Mbit Flex-enabled iba-devices.

ibaLink-VME can be connected within a ring to these devices. But the card cannot communicate with the other devices, only with the Flex master (at the moment only ibaPDA)

- see description chapter 7.2.6

3 Scope of delivery

After unpacking check the completeness and intactness of the delivery.

The scope of delivery includes:

- Device ibaLink-VME
- Manual

4 Safety instructions

4.1 Designated use

The device is an electrical equipment. It may be used only in the following applications:

- Automation of industrial systems
- Measurement data logging and analysis
- Applications of software products (ibaPDA, ibaLogic etc.) and hardware products of iba AG

The device is only to be applied as shown in the Technical Data in chapter 11.

4.2 Special advices



CAUTION

The ESD standards for handling electrostatic sensitive devices must be followed.

Use a ground line or discharge any electrostatic charge from yourself before touching the card.

Avoid direct contact with the connectors.



Warning!

This is a Class A device. This equipment may cause radio interference in residential areas. In this case, the operator will be required to take appropriate measures.

5 System requirements

5.1 Hardware

Coupling to a PC system:

- IBM-compatible PC, Pentium IV 1 GHz, 512 MB RAM, 20 GB HD or better
- At least one fiber optic card of ibaFOB-D type
 - ibaFOB-io-D
 - ibaFOB-2io-D
 - ibaFOB-2i-D optional with extension module ibaFOB-4o-D
 - ibaFOB-4i-D optional with extension module ibaFOB-4o-D
 - ibaFOB-io-ExpressCard

Coupling to an automation system

- iba system connection as partner of the computer coupling
or
- iba I/O device

5.2 Software

Coupling to a PC system

- ibaPDA (32Mbit Flex mode is supported beginning with version 6.29.0)
or
- ibaLogic V4

5.3 PLC or control system

- VME32 or VME64 rack (with a free 6U high slot)
- ibaLink-VME installed in PLC

6 Installation / Deinstallation



⚠ CAUTION

The ESD standards for handling electrostatic sensitive devices must be followed.

Use a ground line or discharge any electrostatic charge from yourself before touching the card. Avoid direct contact with the connectors.

Preferably hold the card only by the front panel.

Each ibaLink-VME occupies a single slot in the VME rack.

6.1 Installing the card



⚠ CAUTION

Before installation / deinstallation of the card switch off the power supply of the VMEbus rack.

Don't plug in or pull out the card under power.

1. Unpack the card carefully. Use a ground line or discharge any electrostatic charge from yourself before touching the card.
2. Put the card with the welded side down on an even, clean and dry surface and make the required settings of the DIP switches.
3. Switch off the VMEbus rack.
4. Take hold of the card by the two slide elements (grips). Move the grips away from each other.
5. Slide the card into the appropriate slot of the VME system carefully.
6. Before sliding in the card to the end make sure that the two guide pins on the rear side of the front panel slide into the dedicated holes in the rack.
7. Move the grips towards each other until they snap in.
8. Push the card firmly into the rack and into the backplane connector(s).
9. Fix the card to the rack with the two screws on the upper and lower end of the front panel.



Special note for installing the ibaLink-VME card in a GE 90/70 system rack

The GE90/70 system rack has no openings for the guide pins of the ibaLink-VME card. If this fact has not been considered when ordering the card, the guide pins have to be removed before installing the card.



6.2 Removing the card

In order to remove the card from the VME rack please follow these steps:

1. Switch off the power supply of the VME rack.
2. Release the screws in the front panel.
3. Press the two slide elements (grips) apart from each other. This will release the card from the backplane connectors.
4. Pull the card out of the slot.

7 Device description

7.1 Connectors and Operational Elements on Front Panel

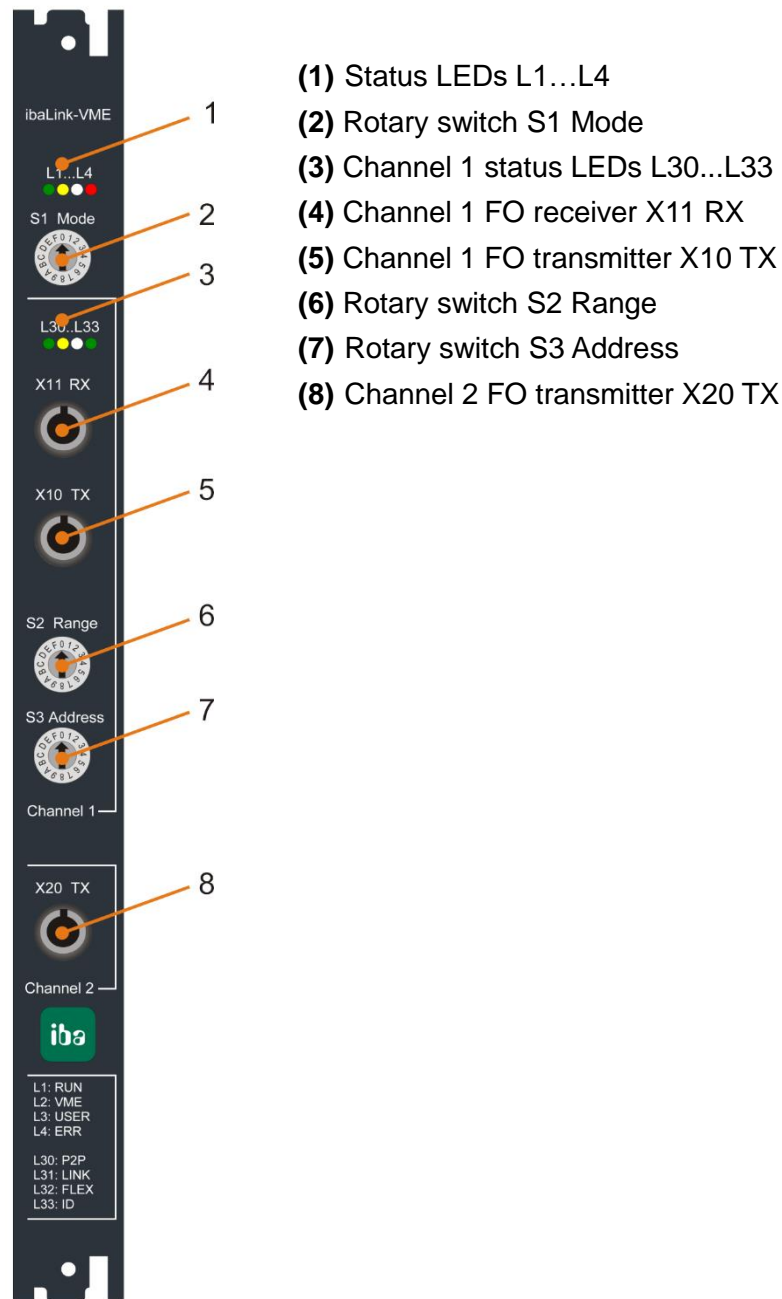

Figure 1 View on front panel of ibaLink-VME

7.1.1 Fiber optic connections

Channel 1: X11 RX (4) and X10 TX (5)

Channel 1 communicates bidirectionally with compatible devices over the RX and TX interface ports. RX realizes the fiber-optic receiver while TX realizes the fiber-optic transmitter.

Possible data transmission see chapter 7.2.

Channel 2: X20 TX (8)

X20 TX realizes the second fiber-optic transmitter (channel 2).

X20 can be used as the second channel output in 3Mbit mode. When working in other modes the X20 output is a copy of the channel 1 output (X10). X20 can be used for diagnostics.

Maximum distance of fiber optic connections

The maximum distance of fiber optic connections between 2 devices depends on various influencing factors. This includes, for example, the specification of the fiber (e.g. 62.5/125 μm , 50/125 μm , etc.), or the attenuation of other components in the fiber optic cable plant such as couplers or patch panels.

However, the maximum distance can be estimated on the basis of the output power of the transmitting interface (TX) or the sensitivity of the receiving interface (RX). A model calculation can be found in chapter 11.3.

The specification of the transmitter's output power and the receiver's sensitivity of the fiber optic components installed in the device can be found in chapter 11.1 "Technical data" under "ibaNet interface".

7.1.2 Rotary switches

S1 „Mode“ (2)

This switch sets the mode of operation for the ibaLink-VME interface card. The modes of operation vary in the used ibaNet protocol, the transmission rate, size and format of the telegrams.

➤ See chapter 7.2 Operation modes.

S2 “Range” (6)

In 3Mbit cascading mode the range switch specifies the range of channels within a cascade to be transmitted over the fiber-optic link.

➤ See also section 7.2.1 and 0 "Cascade Mode 3Mbit".

In 32Mbit P2P mode the range switch is used to select the FO telegram type.

➤ See also section 7.2.5 "ibaNet 32Mbit P2P (mode 4)".

In 32Mbit Flex mode the range switch is not used.

S3 “Address” (7)

In 3Mbit mode this switch defines the starting position of the local data in the daisy-chain. Valid values: 1...8. If channel 1 is not operating in daisy-chain mode the switch setting should be 1.

➤ See also section 7.2.1 and 9.3 Cascade with 3Mbit mode.

In 32Mbit Flex mode the address switch specifies the address of the device within a ring topology of 32Mbit Flex enabled devices. Possible settings: 1...F.

➤ See also section 7.2.6 and 9.4 "Cascade with 32Mbit Flex".

Default settings of the rotary switches:

- S1 Mode: F (32Mbit Flex mode)
- S2 Range: 0
- S3 Address: 1

7.1.3 Status LEDs

Operating state (1)

LED	Status	Description
L1 RUN (green)	blinking off	power on and device functioning properly no power or defect
L2 VME (yellow)	on off	VMEbus access (read or write) to the ibaLink-VME card no VMEbus access
L3 USER (white)		LED can be controlled by the VME host software by writing a register
L4 ERR (red)	on blinking off	internal error in the device configuration fault normal state; after resolution of error, LED automatically resets

Table 1: Operating state LEDs

Channel state (3)

LED	Status	Description
L30 P2P (green)	on off	P2P (Peer-to-Peer) mode is active P2P mode is not active
L31 LINK (yellow)	on blinking off	3Mbit FO communication, good signal reception at RX 3Mbit reception at RX, but the device is not configured for this mode or 32Mbit Flex: TCP/IP traffic received via 32Mbit Flex no 3Mbit signal detected
L32 FLEX (white)	on blinking off	32Mbit signal detected (Flex or P2P) 32Mbit detected, but the device is not configured for this mode no 32Mbit signal detected
L33 ID (green)		LED can be controlled by ibaPDA I/O Manager in 32Mbit Flex mode This could help identifying an ibaLink-VME card in a rack

Table 2: Channel LEDs

No LEDs are assigned for channel 2, since this channel is only an output channel in 3Mbit mode or a copy of channel 1.

7.2 Operation modes

The S1 “Mode” switch specifies the operation mode, especially the used ibaNet protocol, the telegram size and the timebase.

Depending on the operation mode several devices can be cascaded or coupled in peer-to-peer mode. The X20 TX output at channel 2 can be used as independent output channel, or it can be used for diagnostics when the data of channel 1 is mirrored to this output.

S1 Mode switch	ibaNet protocol	Size	Time base	X10 TX	X20 TX	S3 Addr switch	S2 Range switch
0	3Mbit	64A+64D	1 ms	RX+VME1	VME2	1..8	1..8
1	3Mbit	64A+64D	1 ms	RX+VME1	=TX1	1..8	1..8
8	3Mbit P2P	64A+64D	1 ms	VME1	VME2	-	-
9	3Mbit P2P	64A+64D	1 ms	VME1	=TX1	-	-
4	32Mbit P2P	4024 Bytes	50 μ s .. 1.4 ms	VME1	=TX1	-	0..15
5	32Mbit P2P on X10 TX	4024 Bytes	50 μ s .. 1.4 ms	RX+VME1	=TX1		0..15
	3Mbit on RX	64A+64D	1 ms				
F	32Mbit Flex	65 Bytes .. 4060 Bytes	25 μ s .. 1.4 ms	RX+VME1	=TX1	1..15	-

green: compatible with ibaLink-SM-128V-i-2o

yellow: default setting

VME1: Data from VMEbus interface for channel 1

VME2: Data from VMEbus interface for channel 2

RX: received fiber optic data from channel 1 (cascading)

=TX1: copy of X10 TX (can be used as diagnostics output)

7.2.1 ibaNet 3Mbit (mode 0)

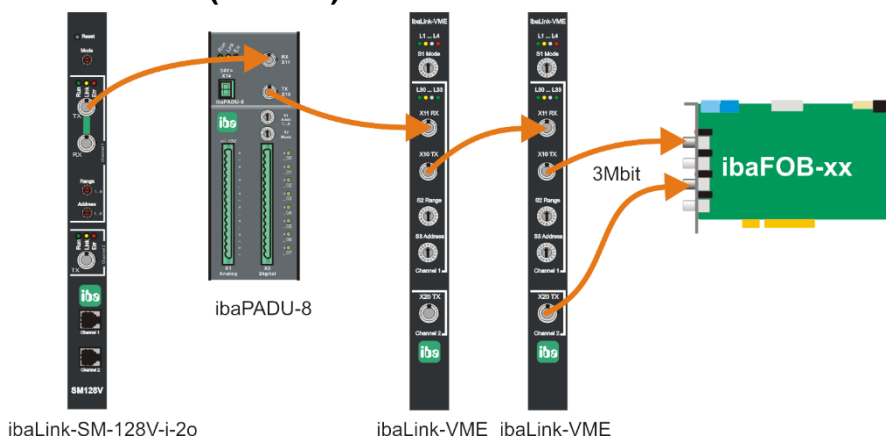

Channel 1 receives and transmits 64 analog and 64 digital input and output signals at 1 ms rate. This mode allows cascading of up to 8 devices. The S2 Range switch specifies the range of channels within a cascade to be transmitted over the fiber-optic link. Valid settings are 1..8 (valid for each 8 digital and 8 analog measured values). Up to 8 x (8 analog + 8 digital signals) can be transmitted in a cascade. The switch should be set to 8, when cascading is not used.

The S3 Address switch defines the starting position of the local data in the daisy-chain (1...8). See also chapter 7.1.2 “Rotary switch S3 Address” and chapter 9.3 Cascade with 3Mbit mode.



Overlapping of Address/Range Settings

When the data ranges of several daisy-chained devices overlap each other, the subsequent card in a daisy-chain will overwrite the values of the previous card. However, all values of the previous card are available in the DPR* of the subsequent card.

* Dual Port RAM

		S2 Range							
		1	2	3	4	5	6	7	8
S3 Address	1	☺	☺	☺	☺	☺	☺	☺	☺
	2	☺	☺	☺	☺	☺	☺	☺	☹
	3	☺	☺	☺	☺	☺	☺	☹	☹
	4	☺	☺	☺	☺	☺	☹	☹	☹
	5	☺	☺	☺	☺	☹	☹	☹	☹
	6	☺	☺	☺	☹	☹	☹	☹	☹
	7	☺	☺	☹	☹	☹	☹	☹	☹
	8	☺	☹	☹	☹	☹	☹	☹	☹

Table 3 Working (☺) and not working (☹) combinations of S2 and S3 switch settings

Channel 2 provides a second independent output for 64 analog and 64 digital signals.

7.2.2 ibaNet 3Mbit with diagnostics (mode 1)

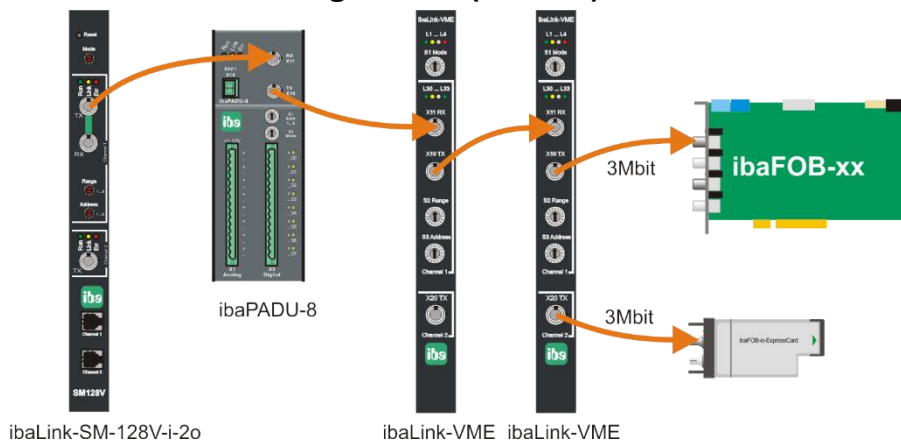

Channel 1 is identical to the previous example (mode 0).

Channel 2: the data of channel 1 is mirrored to channel 2 and can be used for diagnostics.

7.2.3 ibaNet 3Mbit P2P (mode 8)

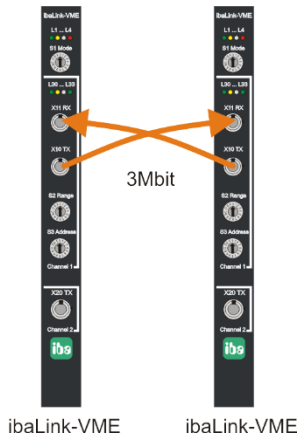

In peer-to-peer-(P2P)-mode 2 cards can be coupled to each other, exchanging data (64 analog and 64 digital signals) periodically in 1 ms (computer coupling). In this operation mode the two VMEbus memory ranges are transmitted from one card to the other. S2 Range switch and S3 Address switch are ignored. The device acts as if address switch is set to 1 and range = 8. Cascading is not possible.

The following devices can also be a partner: ibaLink-SM-128V, ibaLink-SM-64-io, ibaLink-SM-64-SD16 or a Profibus module ibaBM-DPM-S-64. So fast computer coupling between different systems is also possible.

7.2.4 ibaNet 3Mbit P2P with diagnostics (mode 9)

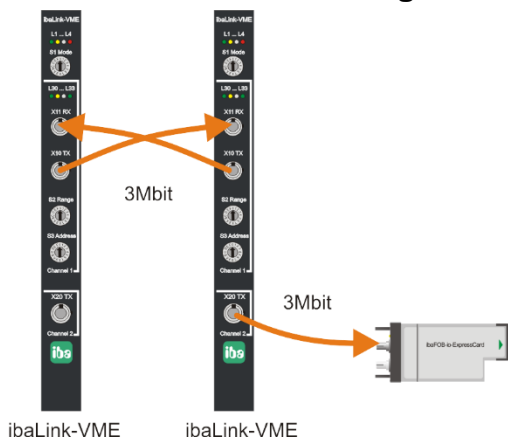

Peer-to-peer-mode is identical to the previous example (mode 8).

Channel 2: the data of channel 1 is mirrored to channel 2 and can be used for diagnostics (e.g. data recording with ibaPDA).

7.2.5 ibaNet 32Mbit P2P (mode 4)

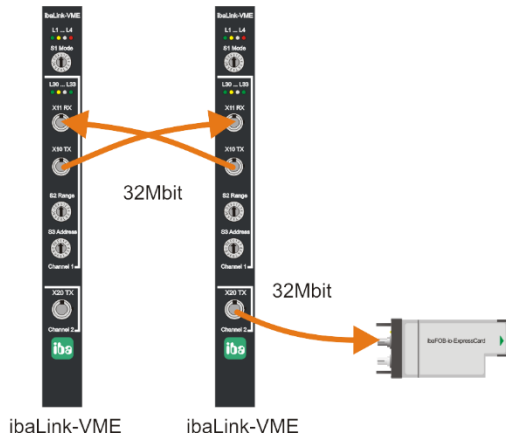

The “fast” peer-to-peer mode is also used to connect two cards, but more signals can be transmitted at a higher data rate.

Channel 2: the data of channel 1 is mirrored to channel 2 and can be used for diagnostics (e.g. data recording with ibaPDA)

The S2 Range switch specifies the transmission mode:

S2 Range switch	Transmission mode
0	64 Integer + 64 Digital in 50 µsec
1	128 Integer + 128 Digital in 100 µsec
2	256 Integer + 256 Digital in 200 µsec
3	512 Integer + 512 Digital in 400 µsec
4	1024 Integer + 1024 Digital in 800 µsec
5	Reserved
6	32 Real + 32 Digital in 50 µsec
7	64 Real + 64 Digital in 100 µsec
8	128 Real + 128 Digital in 200 µsec
9	256 Real + 256 Digital in 400 µsec
A	512 Real + 512 Digital in 1000 µsec
B	Reserved
C	2872 bytes in 1 ms
D	4024 bytes in 1.4 ms
E	Reserved
F	Reserved



Note

The DIP switches for setting the telegram format (Real/Integer) are ignored, since the format is specified by switch S2.

7.2.6 ibaNet mixed mode - 32Mbit P2P transmit and 3Mbit receive (mode 5)

In this mode the 32 Mbit peer-to-peer mode is used to send data to ibaPDA identical to mode 4, but the receiver on Channel 1 receives 64 analog and 64 digital input signals in 3Mbit mode.

Channel 2: the output data of channel 1 is mirrored to channel 2 and can be used for diagnostics (e.g. additional data recording with another ibaPDA system).

Example 1

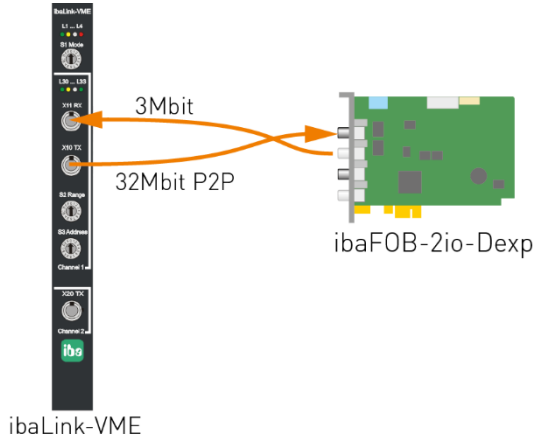

Send data to ibaPDA in 32Mbit P2P (e.g. installed on an HCPi system using Request mode) and receive data from ibaPDA in 3Mbit using the FOB Alarm output module.

Example 2

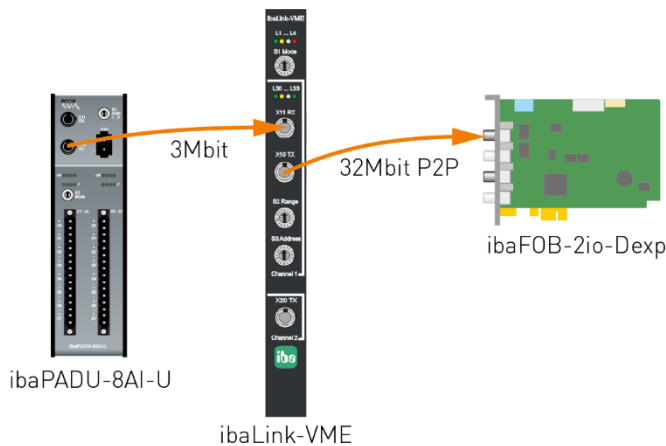

In this example, the ibaLink-VME is also used to send data to ibaPDA in 32 Mbit P2P mode.

The 3Mbit Channel 1 receives 64 analog and 64 digital input signals at 1 ms rate. This mode allows cascading of up to 8 devices.

This allows the automation system, in which the ibaLink-VME card is installed, to use all iba input devices that support 3 Mbit, e.g. ibaPADU-8 devices or components of the ibaNet750-BM series (WAGO / Beckhoff).

The S2 Range switch specifies the transmission mode:

S2 Range switch	Transmission mode
0	64 Integer + 64 Digital in 50 μ sec
1	128 Integer + 128 Digital in 100 μ sec
2	256 Integer + 256 Digital in 200 μ sec
3	512 Integer + 512 Digital in 400 μ sec
4	1024 Integer + 1024 Digital in 800 μ sec
5	Reserved
6	32 Real + 32 Digital in 50 μ sec
7	64 Real + 64 Digital in 100 μ sec
8	128 Real + 128 Digital in 200 μ sec
9	256 Real + 256 Digital in 400 μ sec
A	512 Real + 512 Digital in 1000 μ sec
B	Reserved
C	2872 bytes in 1 ms
D	4024 bytes in 1.4 ms
E	Reserved
F	Reserved

For the 3Mbit receiver on Channel 1, the DIP switches DP1 bit 3 and bit 4 define the endianness and the integer / real mode of the received data. For more details see 0. The S3 Address switch has no function in this mode.

7.2.7 32Mbit Flex (mode F)

Example 1

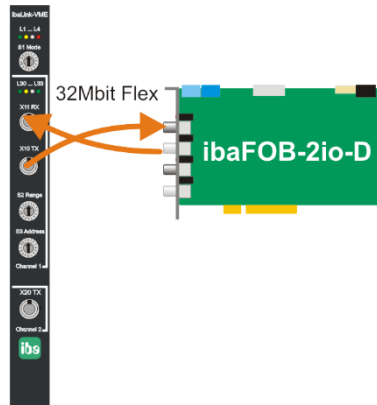

ibaLink-VME

Example 2

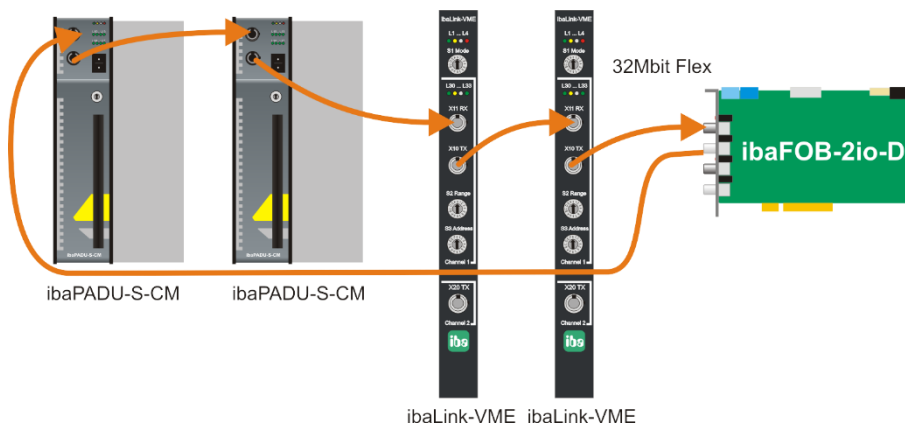

ibaLink-VME ibaLink-VME

The transmission rate can be adjusted flexibly depending on the amount of data (e.g. the fastest rate is 65 bytes at 25 μ s, the maximum amount of data is 4060 bytes at 1.4 ms).

The ibaLink-VME card can be connected with up to 15 devices in a ring topology with 32Mbit Flex. 32Mbit Flex requires a FO card of the ibaFOB-D type for communication. The diagnostic output X20 is not supported yet in 32Mbit Flex mode.

ibaLink-VME should be configured at least once. The configuration is stored on the card until a new configuration is sent from the PC.

The address of the card in a ring is set by the S3 Address switch. The S2 Range switch has no function in this mode.

Device number within the cascade	S3 Address switch position
not allowed	0
Flex Device 1	1
Flex Device 2	2
⋮	⋮
Flex Device 14	E
Flex Device 15	F

7.3 DIP Switches on Board

The DIP switches are located in the lower part of the board. They are used for setting interrupts, data formats and the board's base memory address in the VME address space.

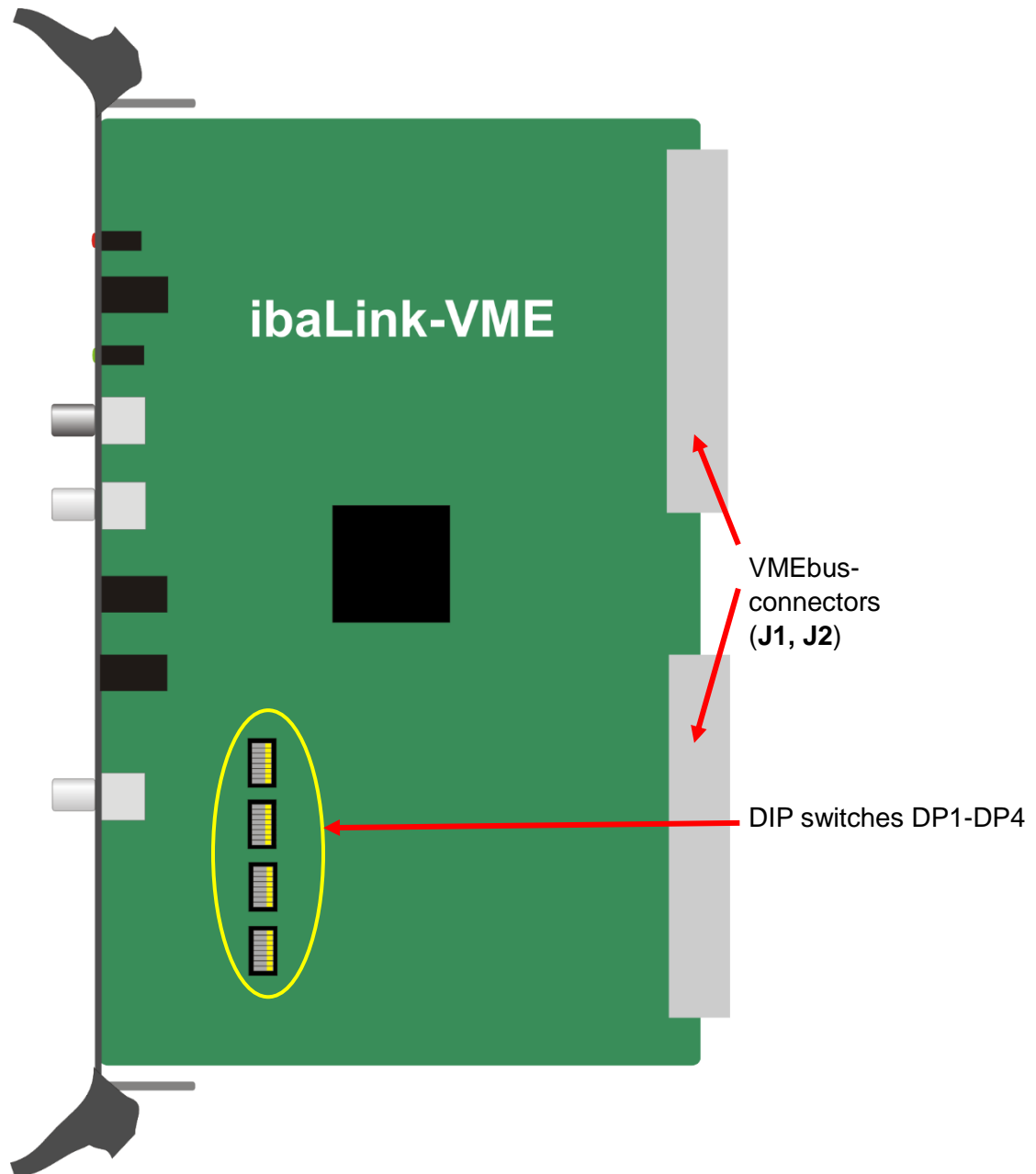

Figure 2 View on assembly side

DIP switch default setting:

- Coherent mode: no
- Format mode: Integer, Little Endian
- Addressing: A32
- VMEbus address: 0x0000 0000

7.3.1 Function of DIP Switches

Bit	ON		OFF
DP1 – Data format			
8	no function	RSVD1	no function
7	no function	RSVD2	no function
6	no function	RSVD3	no function
5	Coherent Mode enabled	COHERENT	Non-coherent
4	Channel 1 Big Endian	CH1-BIG-ENDIAN	Channel 1 Little Endian
3	Channel 1 REAL data	CH1-REAL	Channel 1 INTEGER data
2	Channel 2 Big Endian	CH2-BIG-ENDIAN	Channel 2 Little Endian
1	Channel 2 REAL data	CH2-REAL	Channel 2 INTEGER data
DP2 – Board base address A[39:32] (only used in A40 and A64 modes)			
8	Address bit = 1	A39 (A63)	Address bit = 0
7	Address bit = 1	A38 (A62)	Address bit = 0
6	Address bit = 1	A37 (A61)	Address bit = 0
5	Address bit = 1	A36 (A60)	Address bit = 0
4	Address bit = 1	A35 (A59)	Address bit = 0
3	Address bit = 1	A34 (A58)	Address bit = 0
2	Address bit = 1	A33 (A57)	Address bit = 0
1	Address bit = 1	A32 (A56)	Address bit = 0
DP3 – Address mode and base address			
8	24-bit (or 64-bit) address used	Mode A24	32-bit address used
7	40-bit (or 64-bit) address used	Mode A40	32-bit address used
6	Address bit = 1	A31 (A55)	Address bit = 0
5	Address bit = 1	A30 (A54)	Address bit = 0
4	Address bit = 1	A29 (A53)	Address bit = 0
3	Address bit = 1	A28 (A52)	Address bit = 0
2	Address bit = 1	A27 (A51)	Address bit = 0
1	Address bit = 1	A26 (A50)	Address bit = 0
DP4 – Base address			
8	Address bit = 1	A25 (A49)	Address bit = 0
7	Address bit = 1	A24 (A48)	Address bit = 0
6	Address bit = 1	A23 (A47)	Address bit = 0
5	Address bit = 1	A22 (A46)	Address bit = 0
4	Address bit = 1	A21 (A45)	Address bit = 0
3	Address bit = 1	A20 (A44)	Address bit = 0
2	Address bit = 1	A19 (A43)	Address bit = 0
1	Address bit = 1	A18 (A42)	Address bit = 0

Yellow: default settings

Table 4 Function of DIP switches

Coherent mode (DP1.5)

The coherent mode can be activated here.

Coherent mode means, that data of a processing cycle are transferred in one FO telegram. To enable coherent data transmission proceed as follows:

- After writing to the transmit buffer, the sender has to release the data transfer by setting the 0xE8.7 bit in the DPR. Copying the transmit buffer takes less than 10 μ s, i.e. send requests must not follow each other faster than 10 μ s.
- In coherent mode the receive buffer in DPR is only updated on user request by setting the 0xE8.5 bit in the DPR.

➤ See chapter 10.3, Control/Status/Version registers

The consistence within a 16 bit or 32 bit Dword is guaranteed, even when coherent mode is disabled.

Byte order (DP1.4 and DP1.2)

Byte order settings are only relevant for 3Mbit (S1 = 0, 1, 8, 9) and certain 32Mbit P2P modes (S1 = 4, S2 = 0...B). In 32Mbit P2P with S2 = C or D and in 32Mbit Flex mode (S1 = F) the byte order is configured in ibaPDA.

In mode S1 = 5, DP1.4 defines the byte order of the 3Mbit received data.

Data format (DP1.3 and DP1.1)

Data format settings are only relevant in 3Mbit modes (S1 = 0, 1, 5, 8, 9).

In 32Mbit P2P mode (S1 = 4) the data format is adjusted with the telegram type (Switch S2).

In 32Mbit Flex mode (S1 = F) the data type is configured in ibaPDA.

In mode S1 = 5, DP1.3 defines the integer or real mode of the received data.

Address mode (DP3.8 and DP3.7)

Address mode	DP3.8 (A24 mode)	DP3.7 (A40 mode)	used address switches
A32 mode	OFF	OFF	A31...A18
A24 mode	ON	OFF	A23...A18
A40 mode	OFF	ON	A39...A18
A64 mode	ON	ON	A39...A18 (specify the address bits A63...A42)

7.3.2 Setting the VMEbus Start Address

The lower two DIP switches are used for setting the VME memory address of the card in hex-code.

The assignment of DIP switch bits and address is shown in the picture below with start address 0x77900000 as an example.

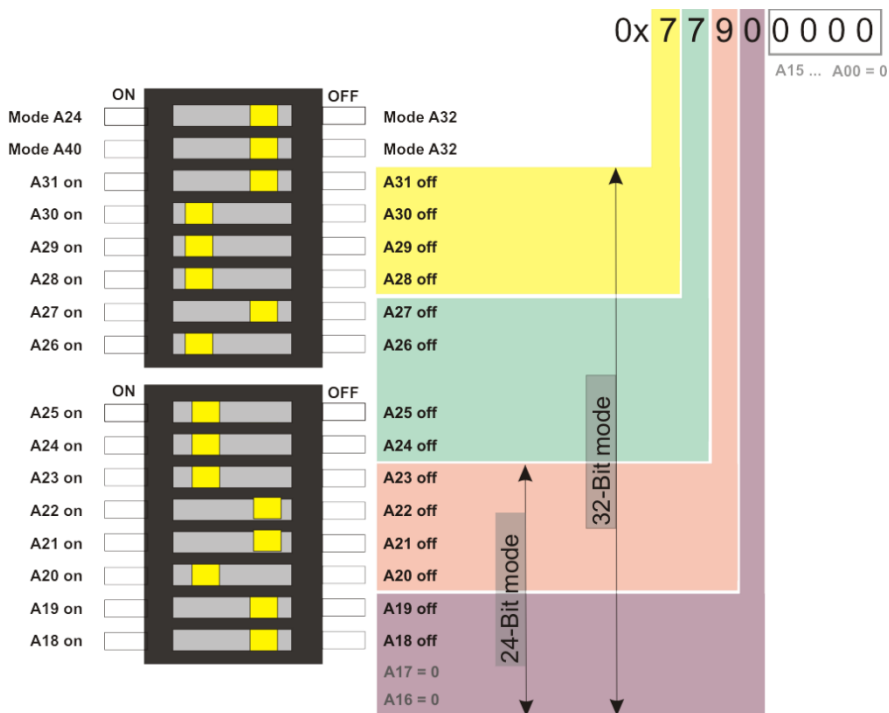

Figure 3 VME memory addressing

The lower four hex digits of the address have the value 0. There are no switches to change these values. The bit A16 and A17 have the fixed value 0 too.

The address setting can be modified from the 19th bit (A18) on. Thus, the value of the 5th hex digit can be 0, 4, 8 or C.

Default setting: 0x0000 0000

8 Settings for Host systems



Note

The following examples base on applications realized with the predecessor ibaLink-SM128, i.e. they apply to ibaLink-VME with 3Mbit mode.

But when using ibaLink-VME it is possible to transfer larger data amounts, faster cycles or coherent data blocks. For that the card must be set to 32Mbit P2P or 32Mbit Flex mode and other functions should be used to transmit the values to the VME side.

8.1 Settings for ALSPA CP80/A800 (AEG Logidyn D)

ALSPA CP80/A800 is the compatible name for the former high performance control system CP80 / A800 with Logidyn D from AEG. It is a VME based system for fast control and regulation, developed by GE Energy Power Conversion GmbH, formerly known as CONVERTEAM GmbH, ALSTOM Power Conversion, AEG-Cegelec or AEG.

In order to use the ibaLink-VME board in this system it is required to use a modified version with a single connector to the 16 bit VME backplane. In the lower part of the system's backplane in the rack there is the PMB bus.

Engineering notes for ibaLink with ALSPA CP80/A800 (Logidyn D)

On the next page you'll find an example with card settings for using the card in 24 bit addressing mode and delivering integer values for analog signals.

Possible address settings might be as follows:

Addresses analog (integer) channel 1:0xE43802

Addresses analog (integer) channel 2:0xE43902

Addresses digital channel 1:0xE42420

Addresses digital channel 2:0xE42428

Address lifesign counter:0xE40080

The corresponding memory access may be managed in the LogiCAD-program by sub-routines (UP). These subprograms are required to map the signals to be measured to the memory addresses of the board.

A request solution for selecting data to be measured over ibaPDA is not available. The signals have to be "wired" in the application program.

The usage of more than one card in a rack is permitted.



Tip

A sample program (*.O32 object file) is available on request from iba AG, Germany, which uses the addresses mentioned above in this example. Furthermore, we can provide a LogiCAD documentation of a sample application. The object must be linked to the Logidyn application program, i. e. entered in the *.ind file, using LogiTool or a command on the DOS shell.

The subprogram can handle up to 64 integer and 64 binary signals in groups of 16 signals in the LogiCAD program. The signals are transmitted to ibaPDA over the first FO channel of the board.

If the addresses mentioned above are already used for other components in the existent application, the subroutine must be compiled with reference to other address ranges. Therefore, a DSI PC card is required.

8.1.1 Card Settings

The yellow marks show the switch position.

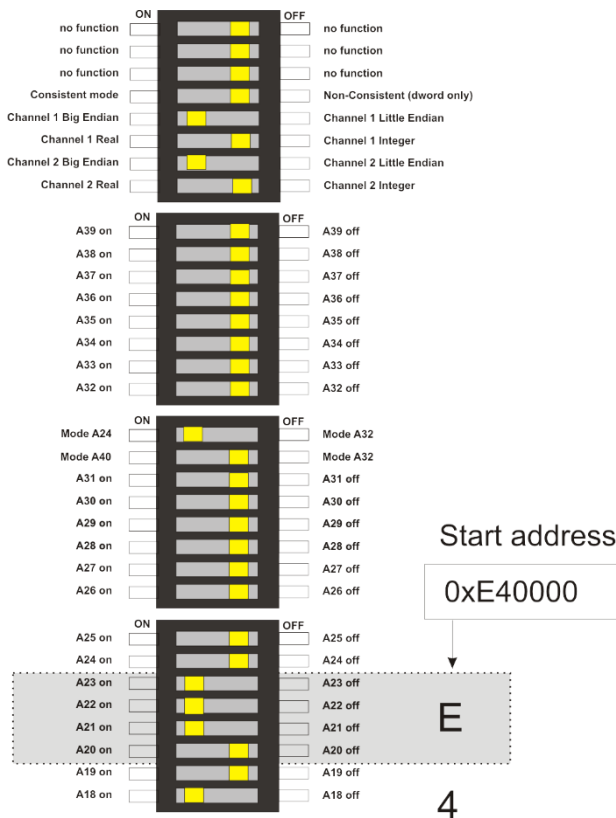

Settings:

Mode: A24 (24-bit mode)

Start address memory range:
0xE40000

Byte order: Big Endian

Data format: Integer

Figure 4 DIP switch, settings for ALSPA CP80/A800 (one, or first ibaLink-VME card)

8.1.2 Switch Settings on Front Panel of ibaLink-VME

3Mbit protocol: switch S1 = 0, S2 = 8, S3 = 1

32Mbit P2P: switch S1 = 4, S2 depending on data amount, S3 = x

32Mbit Flex: S1 = F, S2 = x, S3 = 1...F (device address).

8.2 Settings for ALSPA C80 HPC (Logidyn D2)

The system ALSPA C80 HPC is a VME based system for fast control and regulation, developed by GE Energy Power Conversion, Berlin, Germany. The ibaLink-VME interface card can be used in a HPC rack with Logidyn D2.



Note

For the older system A800 / Logidyn D1 only the modified version of the board (ibaLink-VME-16Bit) can be used.

8.2.1 Engineering notes for ibaLink-VME with ALSPA C80 HPC (Logidyn D2)

Four VMEbus addresses are reserved by GE Energy for the operation of ibaLink-VME cards. Hence up to 4 ibaLink-VME cards can be used in one HPC rack. The memory ranges are 512 kByte wide, though only 256 kByte are currently used, with reference for future extensions.

Parameterizing the VME bus address in HPC (LogiCAD)

A32 base address: 0x77900000

A32 size: 0x00040000 (256 kByte)

8.2.2 Card Settings

The yellow marks show the switch position.

Settings:

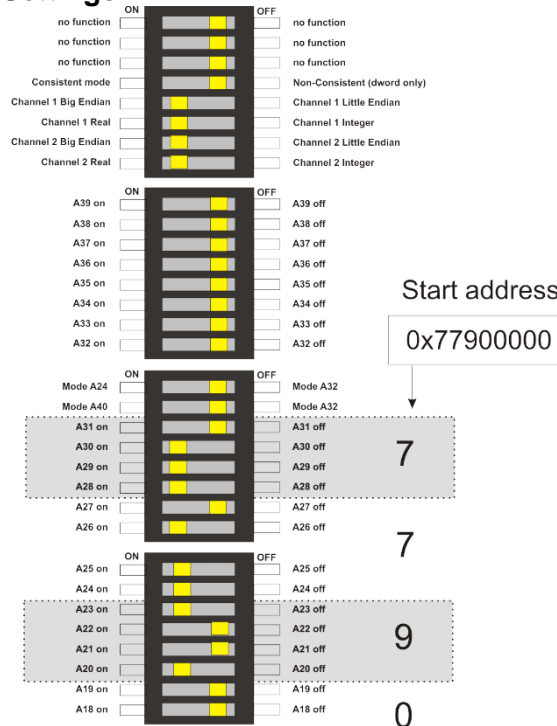

Mode: A32 (32-bit mode)

Start address memory range:
0x77900000

Byte order: Big Endian

Data format: REAL

Figure 5 DIP switch, settings for ALSPA C80 HPC (one, respectively first ibaLink-VME card)

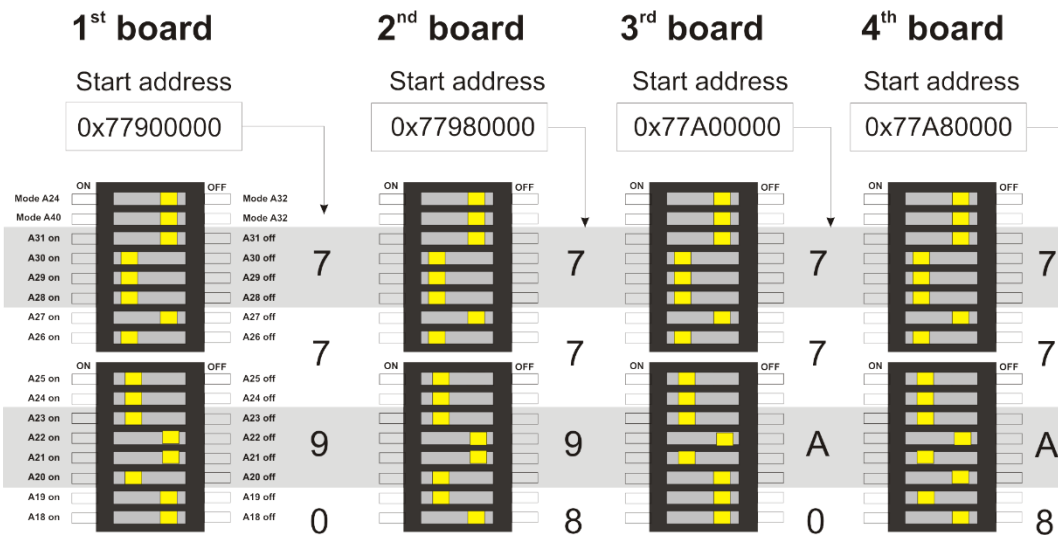

Figure 6 DIP switch, settings for up to four ibaLink-VME cards in ALSPA C80 HPC

8.2.3 Use of the ibaLink-VME in SM128 compatibility mode

Transferring values to the VME memory range

In order to write data into the memory range of the ibaLink-VME card, a subroutine – the so called parameter block “IBA_SM128V” – must be used in the application program. One parameter block has to be programmed for each ibaLink-VME card in the rack. Input parameters are the number of the VME block, the VMEB1 block and the slot number where the card is installed. A sample application is available on request from GE Energy Berlin, Germany. When used in SM128 compatible mode the analog values (float) are assigned to the VME block, the digital values (flags) are assigned to the VMEB1 block.

When used in 32Mbit Flex mode, other program blocks are required (special program blocks need to be programmed).

Administration in HPC (LogiCAD)

An administration block and a time management (synchronization) must be programmed for operation of one or more ibaLink-VME cards.

Link Statement (LogiCAD)

The application program must include a link statement to the library SM128\IBA.

Signal Assignment to Measurement Channels (LogiCAD)

The analog and digital signals to be transmitted should be named according to the module structure of ibaPDA for better understanding.

Hardware Configuration in HPC

The ibaLink-VME card has to be entered as OEM device in the hardware configuration.

Settings for Hardware (WINRDTM):



OEM

Slot: 12

Baugruppenname: SM128V

Herstellername: IBA

A32-Basisadresse: 0x77900000

A32-Größe: 0x00040000

A24-Basisadresse: 0x00000000

A24-Größe: 0x00000000

A16-Basisadresse: 0x00000000

A16-Größe: 0x00000000

OK Abbrechen RCSL

8.2.3.1 Switch Settings on Front Panel of ibaLink-VME

3Mbit protocol: switch S1 = 0, S2 = 8, S3 = 1.

8.2.4 Use of the ibaLink-VME in 32Mbit P2P mode

Additional engineering notes for ibaLink-VME with ALSPA C80 HPC (Logidyn D2)

By using the ibaLink-VME in 32Mbit P2P mode, 974 float values and 1024 bits can be transferred using one single board. The S2 switch should be set to mode D, transferring 4024 bytes in 1.4 ms.



Note

To use this P2P mode, the firmware version of the ibaLink-VME must be v02.02.001 or higher. It is also recommended to install ibaPDA V6.38.0 or higher in order to have the correct default settings of the ibaLink-VME P2P module in mode D.

Transferring values to the VME memory range

In order to write data into the memory range of the ibaLink-VME card, a subroutine – the so called parameter block “VMIC_IBA” – must be used in the application program.

This block was originally used to write to reflective memory.

This block is able to write 32 blocks of analog float values at board offset 0x5000, and 32 blocks of digital values at board offset 0x6000.

To be able to use this block, the firmware

- remaps the 0x5000-0x5F37 analog region to offset 0xC000-0XCF37.
- remaps the 0x6000-0x607F digital region to offset 0xCF38-0XCFBF.

0xC000 is the location of the 4K Transmit buffer for 32Mbit P2P and Flex mode.

One parameter block has to be programmed for each ibaLink-VME card in the rack. Input parameters are

- the number of the first VME block,
- the first VMEB1 block,
- number of blocks and
- the slot number where the card is installed.

A sample application is available on request from iba, however iba does not take any responsibility to adapt this sample to your equipment.

One data transfer block in LogiCAD consists of 2 VME blocks (with 16 analog float values each) and 1 VMEB1 (with 32 bits each).

So to use the complete range of 4024 bytes, 64 VME blocks (61 effectively used) and 32 VMEB1 blocks must be generated. On request, a VBScript can be supplied to generate a TXT file with the VME and VMEB1 blocks, which can be used to import into LogiCAD.

VME : VME-Data-Exchange 4 byte

Com.

	EXT Name	Commentary
1.	<input checked="" type="checkbox"/> PDA_F0001	
2.	<input checked="" type="checkbox"/> PDA_F0002	
3.	<input checked="" type="checkbox"/> PDA_F0003	
4.	<input checked="" type="checkbox"/> PDA_F0004	
5.	<input checked="" type="checkbox"/> PDA_F0005	
6.	<input checked="" type="checkbox"/> PDA_F0006	
7.	<input checked="" type="checkbox"/> PDA_F0007	
8.	<input checked="" type="checkbox"/> PDA_F0008	
9.	<input checked="" type="checkbox"/> PDA_F0009	
10.	<input checked="" type="checkbox"/> PDA_F0010	
11.	<input checked="" type="checkbox"/> PDA_F0011	
12.	<input checked="" type="checkbox"/> PDA_F0012	
13.	<input checked="" type="checkbox"/> PDA_F0013	
14.	<input checked="" type="checkbox"/> PDA_F0014	
15.	<input checked="" type="checkbox"/> PDA_F0015	
16.	<input checked="" type="checkbox"/> PDA_F0016	

VMEB1: VME-Data-Exchange binary

Com.

	EXT Name		EXT Name
1.	<input checked="" type="checkbox"/> PDA_B0001	2.	<input checked="" type="checkbox"/> PDA_B0002
3.	<input checked="" type="checkbox"/> PDA_B0003	4.	<input checked="" type="checkbox"/> PDA_B0004
5.	<input checked="" type="checkbox"/> PDA_B0005	6.	<input checked="" type="checkbox"/> PDA_B0006
7.	<input checked="" type="checkbox"/> PDA_B0007	8.	<input checked="" type="checkbox"/> PDA_B0008
9.	<input checked="" type="checkbox"/> PDA_B0009	10.	<input checked="" type="checkbox"/> PDA_B0010
11.	<input checked="" type="checkbox"/> PDA_B0011	12.	<input checked="" type="checkbox"/> PDA_B0012
13.	<input checked="" type="checkbox"/> PDA_B0013	14.	<input checked="" type="checkbox"/> PDA_B0014
15.	<input checked="" type="checkbox"/> PDA_B0015	16.	<input checked="" type="checkbox"/> PDA_B0016
17.	<input checked="" type="checkbox"/> PDA_B0017	18.	<input checked="" type="checkbox"/> PDA_B0018
19.	<input checked="" type="checkbox"/> PDA_B0019	20.	<input checked="" type="checkbox"/> PDA_B0020
21.	<input checked="" type="checkbox"/> PDA_B0021	22.	<input checked="" type="checkbox"/> PDA_B0022
23.	<input checked="" type="checkbox"/> PDA_B0023	24.	<input checked="" type="checkbox"/> PDA_B0024
25.	<input checked="" type="checkbox"/> PDA_B0025	26.	<input checked="" type="checkbox"/> PDA_B0026
27.	<input checked="" type="checkbox"/> PDA_B0027	28.	<input checked="" type="checkbox"/> PDA_B0028
29.	<input checked="" type="checkbox"/> PDA_B0029	30.	<input checked="" type="checkbox"/> PDA_B0030
31.	<input checked="" type="checkbox"/> PDA_B0031	32.	<input checked="" type="checkbox"/> PDA_B0032

Administration in HPC (LogiCAD)

A VMIC_IBA block and a time management (synchronization) must be programmed for operation of one or more ibaLink-VME cards.

Link Statement (LogiCAD)

The application program must include a link statement to the library LIB386\VMIC_IBA.LIB

Signal Assignment to Measurement Channels (LogiCAD)

The analog and digital signals to be transmitted should be named according to the module structure of ibaPDA for better understanding.

Hardware Configuration in HPC

The ibaLink-VME card has to be entered as OEM device in the hardware configuration.

Settings for Hardware (WINRDTM):

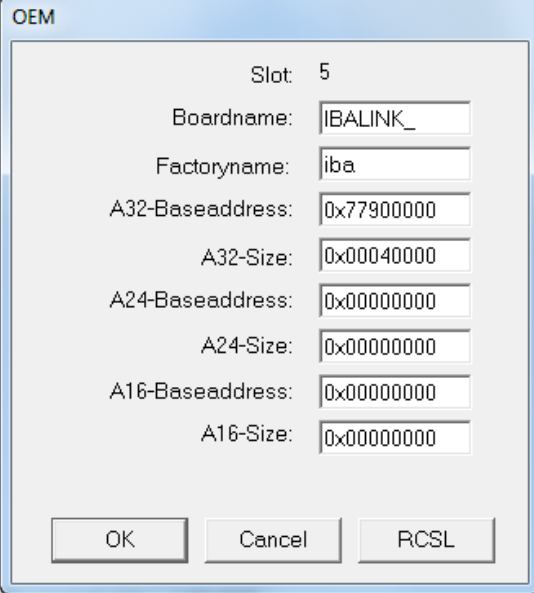

OEM

Slot: 5

Boardname: IBALINK_

Factoryname: iba

A32-Baseaddress: 0x77900000

A32-Size: 0x00040000

A24-Baseaddress: 0x00000000

A24-Size: 0x00000000

A16-Baseaddress: 0x00000000

A16-Size: 0x00000000

OK Cancel RCSL

8.2.4.1 Switch Settings on Front Panel of ibaLink-VME

32Mbit P2P: switch S1 = 4, S2 = D, S3 = x

8.2.4.2 Specific settings in ibaPDA

See chapter [Configuration in 32Mbit P2P mode](#) for setting up a P2P module in ibaPDA.

In ibaPDA V6.38.0 or higher, adding a new module with S2 range switch set to D will automatically set the number of analog signals to 974 and the number of digital signals to 1024. Also the offsets for the 974 analog and 1024 digital signals are preset accordingly. Both analog and digital signals must be swapped as depicted in the screenshot below

ibaLink-VME (P2P) (32)

General

Analog

Digital

Basic	
Module Type	ibaLink-VME (P2P)
Locked	False
Enabled	True
Name	ibaLink-VME (P2P)
Module No.	32
Timebase	0.05 ms
Use name as prefix	False
Advanced	
Swap analog signals	No swap
FOB	
S2 range switch	0: 64 Int / 64 Dig (50µs)
Telegram timebase	50 µs
Advanced	
Swap digital signals	False
Read digital signals	32 bit
Module Layout	
No. analog signals	64
No. digital signals	64

S2 range switch
 Select the value for the S2 range switch. The S1 mode switch should be set to 4 (= 32 MBit/s P2P mode).



Advanced mode

8.2.4.3 Example of the use of the VMIC_IBA block in LogiCAD

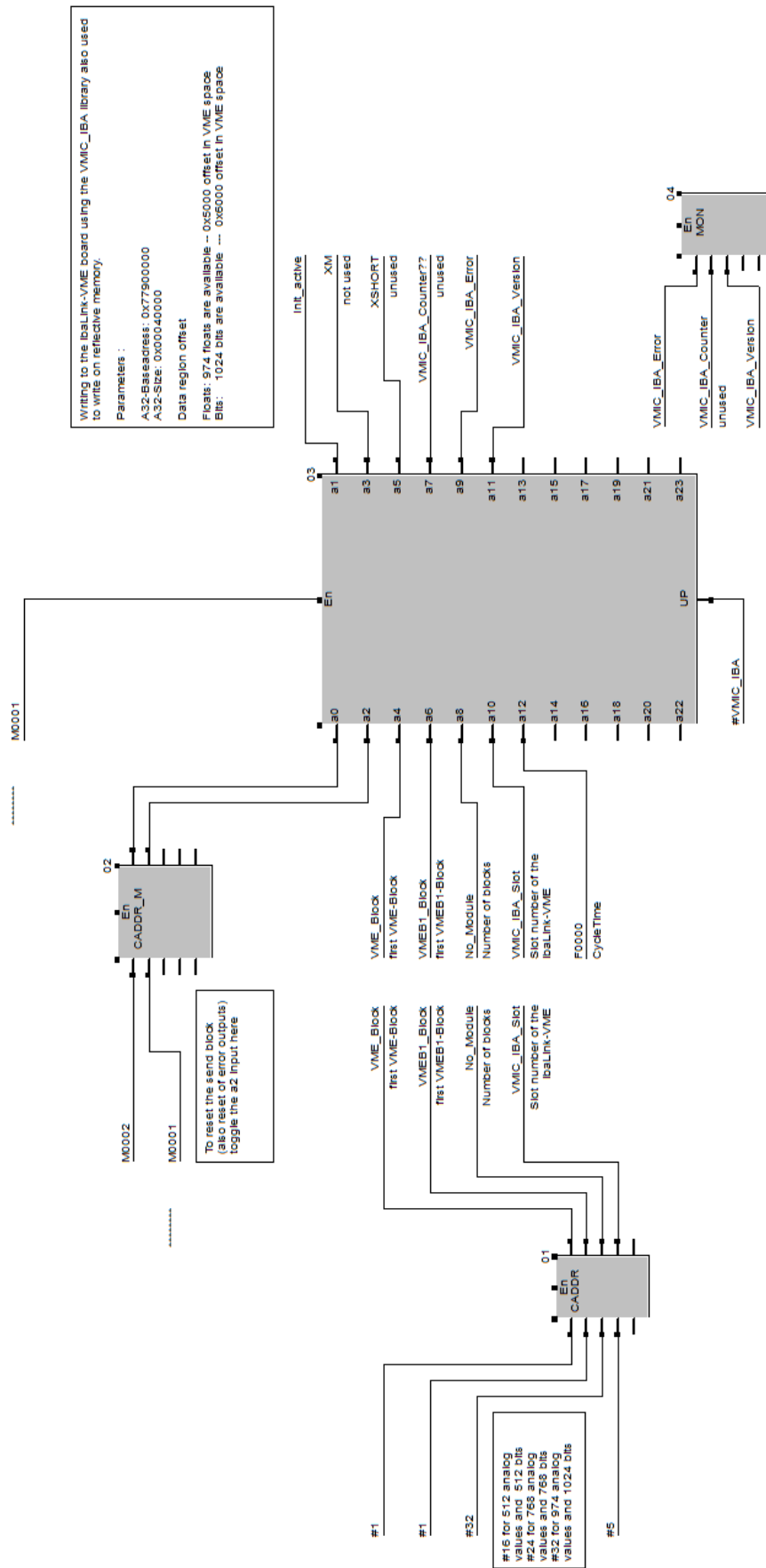

8.3 Settings for HPCi

The system ALSPA C80 HPCi is a VME based system for fast control and regulation, developed by GE Energy. It is the successor of the ALSPA C80 HPC (Logidyn D2) system. The standard version of the ibaLink-VME interface card can be used in an HPCi rack with operating system VxWorks and programming system ALSPA P80i.

8.3.1 Engineering notes

Four VMEbus addresses are reserved by GE Energy for the operation of ibaLink-VME cards. Hence up to four cards can be used in one HPC rack. The memory ranges are 512 kByte wide, though only 256 kByte are currently used, with reference for future extensions.

Parameterizing the VMEbus address in HPCi (P80i)

A32 base address: 0x77900000

A32 size: 0x00040000 (256 kByte)

8.3.2 Card Settings

The yellow marks show the switch position.

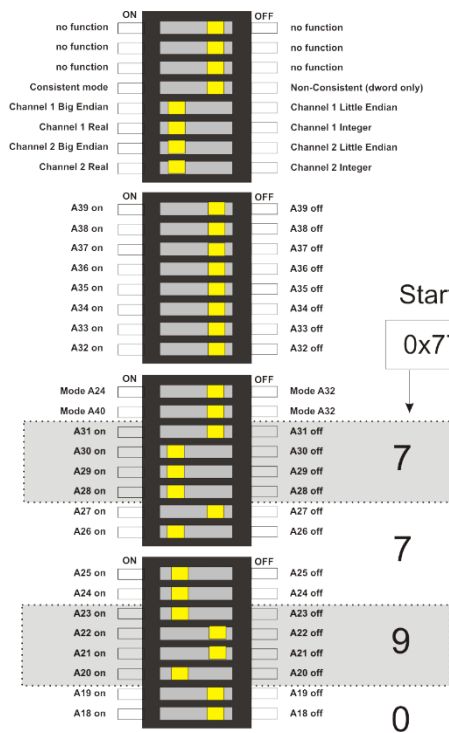

Settings:

Mode: A32 (32-bit mode)

Start address memory range: 0x77900000

Byte order: Big Endian

Data format: REAL

Figure 7 DIP switch, settings for ALSPA C80 HPCi (one, respectively first ibaLink-VME card)

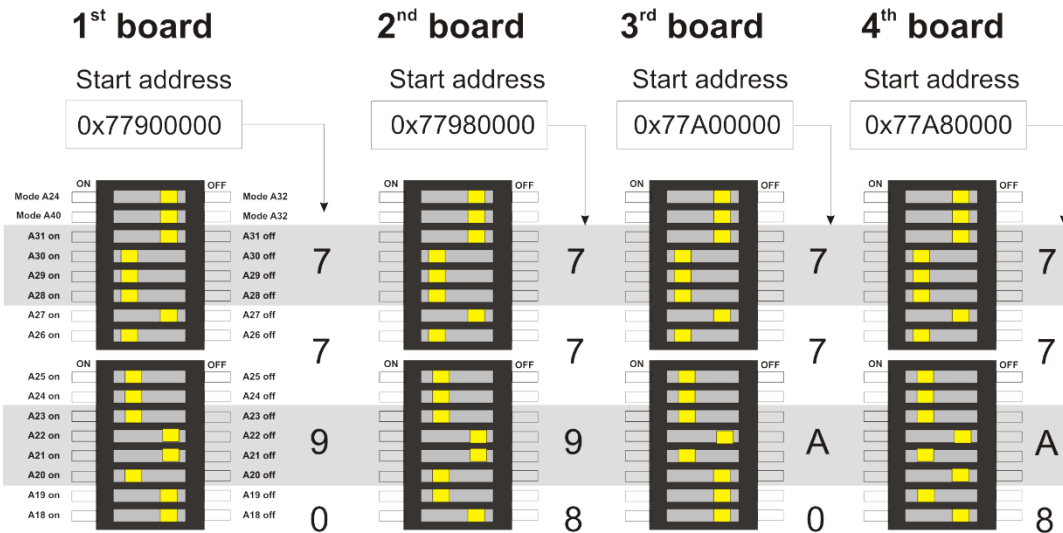

Figure 8 DIP switch, settings for up to four ibaLink-VME cards in ALSPA C80 HPCi

8.3.3 Use of the ibaLink-VME in SM128 compatibility mode

8.3.3.1 Writing the data into the VME memory range

In order to write data into the VME memory range the corresponding VMEWRT function blocks must be included in the application program.

Example for writing analog and digital signals on **channel 1** of the first board with base address 0x77900000:

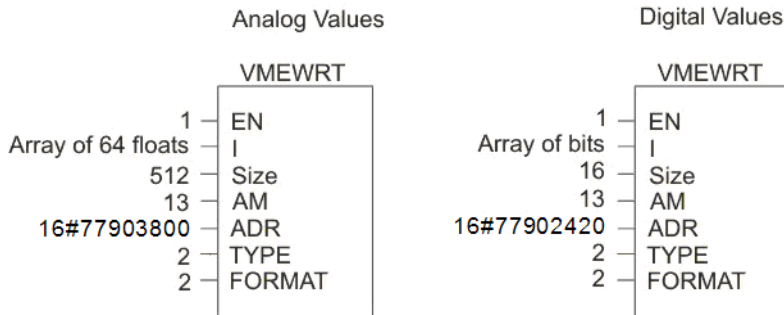

In SM128 mode, the SM128 RX/TX buffers are used.

See chapter [SM128 RX/TX](#) for more details about the different address offsets to be used.

8.3.3.2 Switch Settings on Front Panel of ibaLink-VME

3Mbit protocol: switch S1 = 0, S2 = 8, S3 = 1

8.3.4 Use of the ibaLink-VME in 32Mbit P2P mode or 32Mbit Flex mode

8.3.4.1 Writing the data into the VME memory range

In order to write data into the VME memory range the corresponding VMEWRT function blocks must be included in the application program.

Example for writing analog and digital signals on the first board with base address 0x77900000:

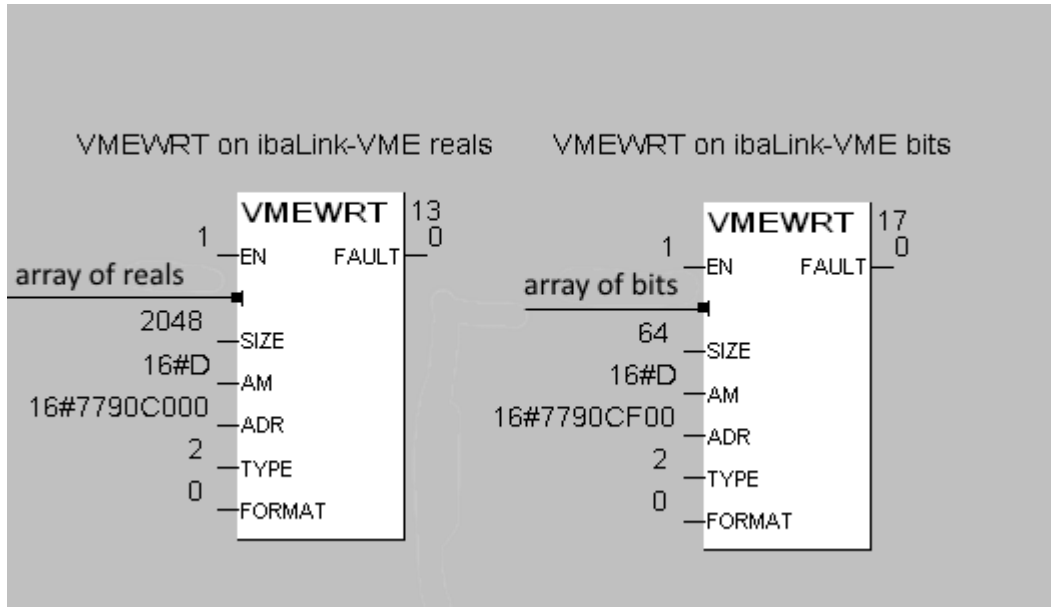

In P2P mode or Flex mode, the 4K RX/TX buffers are used.

See chapter [4K RX/TX buffers](#) for more details about the different address offsets to be used.

8.3.4.2 Switch Settings on Front Panel of ibaLink-VME

32Mbit P2P: switch S1 = 4, S2 depending on data amount, S3 = x

32Mbit Flex: S1 = F, S2 = x, S3 = 1...F (device address).

8.3.5 Use of the ibaLink-VME in mixed mode: 32Mbit P2P transmit and 3Mbit receive

8.3.5.1 Writing the data into the VME memory range

This procedure is identical to the one described in chapter 8.3.4.1

8.3.5.2 Reading the received data from the VME memory

In this mode, the SM128 RX buffers are used.

See chapter [SM128 RX/TX](#) for more details about the different address offsets to be used.

In order to read the data from the VME memory range the corresponding VMERD function blocks must be included in the application program.

Example for reading analog and digital signals on the first board with base address 0x77900000:

For reading the **digital signals**, 8 bytes (2 DWORD) are read from offset 0x2400. Then these DWORD values converted to 64 BOOL values with the function block DW_TO_BA.

Reading the **analog signals** on offset 0x3000:

- First of all a 4 byte VMERD is done on offset 0x1800 to determine the DP1.3 DIP switch setting for integer or real mode. (= bit 7 on 0x1801, due to the endianness set to Big Endian, bit 23 in the DWORD at 0x1800) .
- Depending on this mode setting, either 64 integer values or 64 real values are read from offset 0x3000.
- The integer values are converted from Short Integer to DINT values using the user defined function block 64_SI_TO_DI

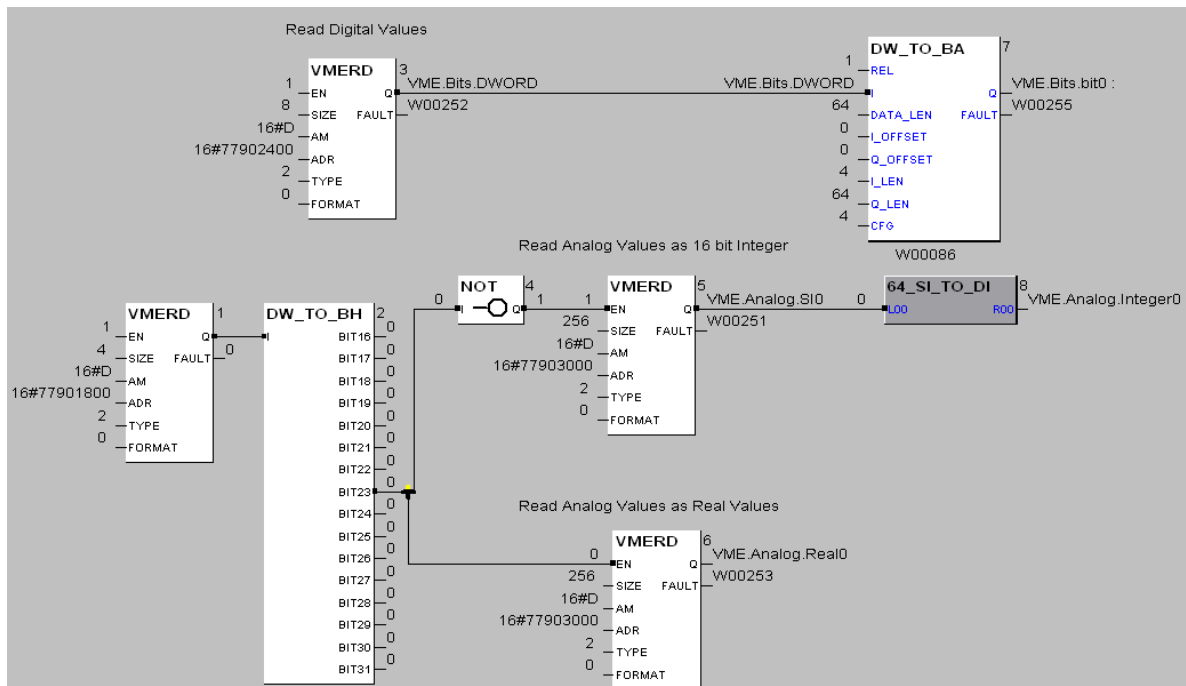

8.3.5.3 Switch Settings on the ibaLink-VME

For the transmitted data:

- Switch S1 = 5, S2 depending on data amount, S3 = x

For the received data:

- Switch S1 = 5, S3 = x
- DP1.3 and DP1.4 must be set accordingly for channel 1. Example below shows the default values (Real mode and Big Endian)



8.4 Settings for GE 90/70

8.4.1 Card settings

The yellow marks show the switch position.



Settings:

Mode: A24 (24-bit mode)

Start address memory range:
0x00A0 0000

Byte order: Big Endian

Data format: REAL

Figure 9 DIP switch, settings for GE 90/70 (one, respectively first ibaLink-VME card)

8.4.2 Switch Settings on Front Panel of ibaLink-VME

3Mbit protocol: switch S1 = 0, S2 = 8, S3 = 1

32Mbit P2P: switch S1 = 4, S2 depending on data amount, S3 = x

32Mbit Flex: S1 = F, S2 = x, S3 = 1...F (device address).

8.5 Settings for SIMATIC TDC

Beginning with version 6.1 of the D7-SYS configuration package, the ibaLink-VME board can be used in SIMATIC TDC.

8.5.1 Engineering notes for Simatic TDC

The “universal module SB590” must be configured with the master program (HWConfig).

Settings in “Properties”, “Parameter” tab:

- Data access: Peripherals (I/O)
- Addresses: A32
- Size in address area: 1 MB
- no auto slot ID

The only modification of the default values is to unselect the option "auto Slot ID".

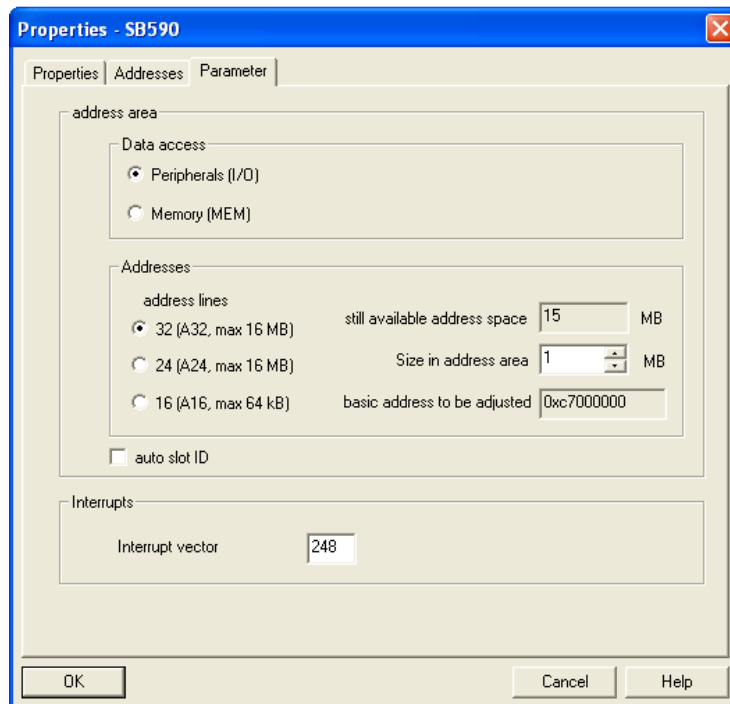

Important note

When using an ibaLink-VME board in a Siemens Simatic TDC automation system a Simatic TDC module must not be inserted to the right of the ibaLink-VME board in a TDC rack! Due to the dynamic address allocation, a required initializing signal to the TDC module is not transmitted via the slot where an ibaLink-VME board is inserted. The TDC module cannot answer and prevents correct initialization. As a result the TDC system cannot boot up.

The ibaLink-VME card occupies a memory range of 256 KByte. But D7-Sys reserves at least 1 MByte by default. The addresses of all cards can be found in the hardware engineering.

⚠ CAUTION

After having modified the hardware configuration, verify the address. The access to an address which is not allowed causes the fatal error "H".

Writing the data into the VME memory range

In order to write data into the VME memory range a functional block must be included in the application plan. One or more blocks are to be used per inserted card.

Block example:

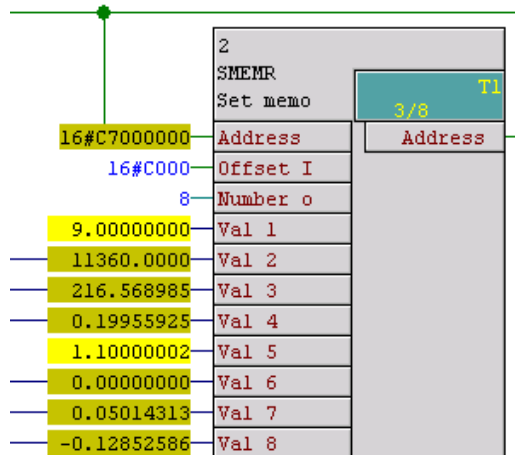

Important note

These functional modules are not provided by iba. Please contact the local Siemens branch office or Siemens AG in Erlangen, Germany.

8.5.2 Card settings

The yellow marks show the switch position.

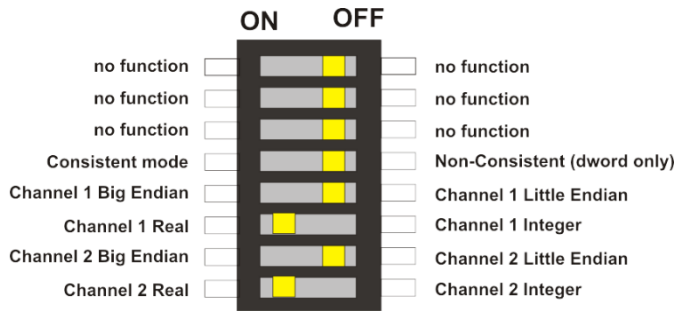

Figure 10: DIP switch, settings for SIMATIC TDC (one, respectively first ibaLink-VME card)

Settings:

Mode: A32

Byte order: Little Endian

Data format: REAL (according to the data format, which is supported by the functional module).

Setting the memory address on the card:

Example: start address 0xC700 0000 (see in HW-Config)

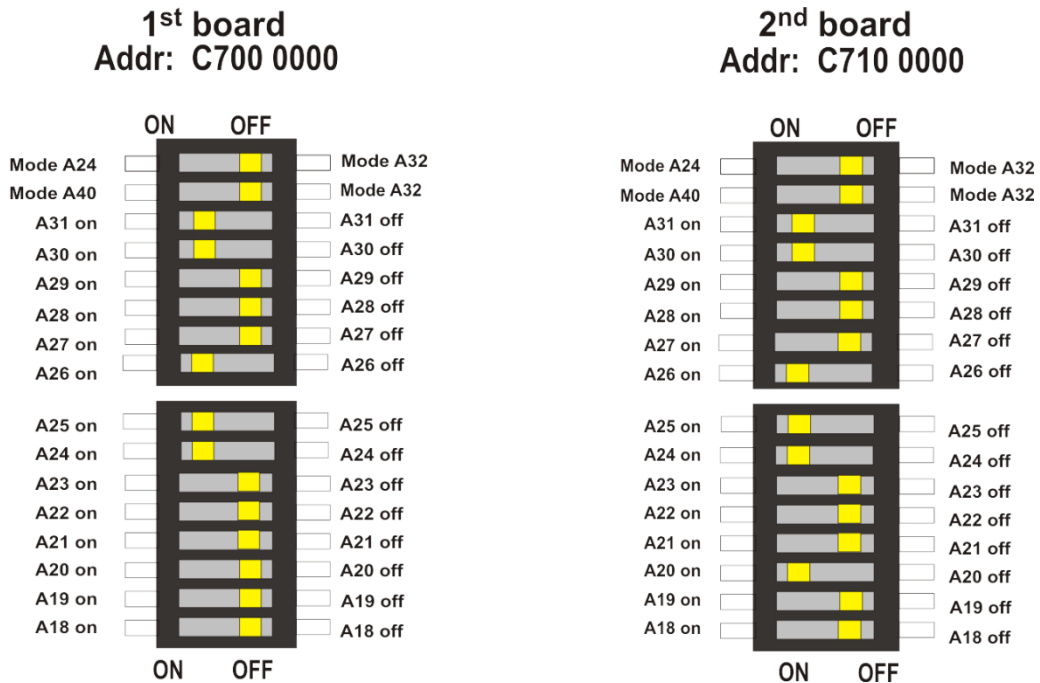

Figure 11: DIP switch, settings for SIMATIC TDC (two ibaLink-VME cards)

8.5.3 Switch Settings on Front Panel of ibaLink-VME

3Mbit protocol: switch S1 = 0, S2 = 8, S3 = 1

32Mbit P2P: switch S1 = 4, S2 depending on data amount, S3 = x

32Mbit Flex: S1 = F, S2 = x, S3 = 1...F (device address).

9 System Topologies

Multiple system topologies are possible with ibaLink-VME. You find application examples with the corresponding operation mode settings in chapter 7.2 Operation modes.

9.1 ibaPDA Application

Depending on the FO protocol it is necessary to use one, two or three fiber-optic links.

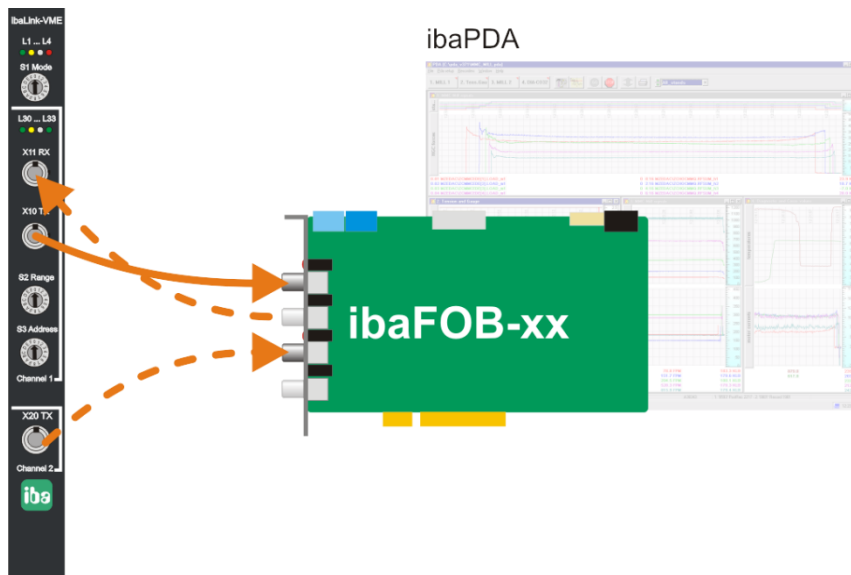

Figure 12 ibaLink-VME with ibaPDA

9.1.1 Configuration in 3Mbit mode

In classic combination of ibaLink-VME and ibaPDA the two fiber-optic output links are connected to input links on ibaFOB-cards. Each link transmits 64 analog and 64 digital signals, i.e. a total of 128 signals.

For outputs from ibaPDA to ibaLink-VME, a FO output link and a FO connection to the RX port of ibaLink-VME is necessary. In ibaPDA I/O manager add a module "FOB alarm" at the connected link and specify the desired analog and digital output data.



Other documentation

Please refer to the "ibaLink-SM-128V-i-2o" manual.

9.1.2 Configuration in 32Mbit P2P mode (4) and mixed mode (5)

9.1.2.1 Common settings for both modes

When using 32Mbit P2P mode or mixed mode, connect a simplex FO cable from TX1 or TX2 to the ibaFOB-D card. In ibaPDA I/O manager add an „ibaLink-VME (P2P)“ module at the connected link and specify the connection mode in the field “S2 range switch”, which corresponds to the S2 switch setting. You can also use the „Autodetect“ function.

Outputs from ibaPDA to ibaLink-VME are not supported in 32Mbit P2P mode, only in mixed mode.

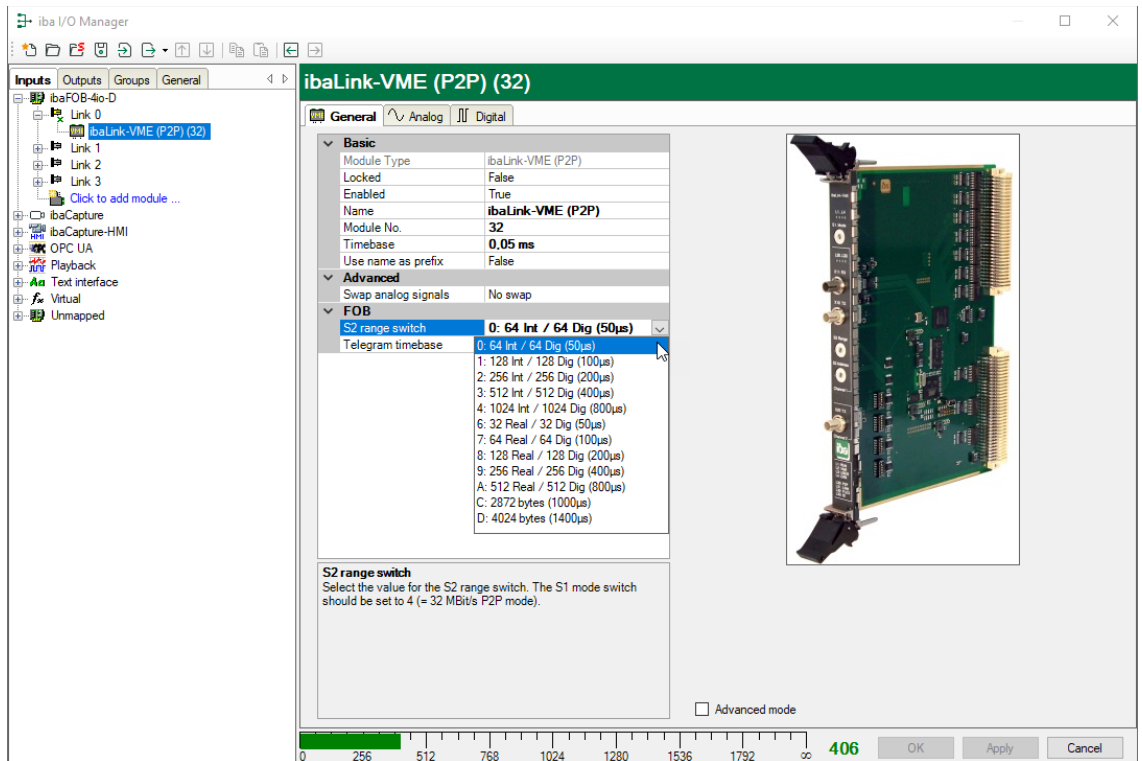

Figure 13 ibaLink-VME (P2P) module

Advanced Mode

If you enable the option „Advanced Mode“ you can make some additional settings.

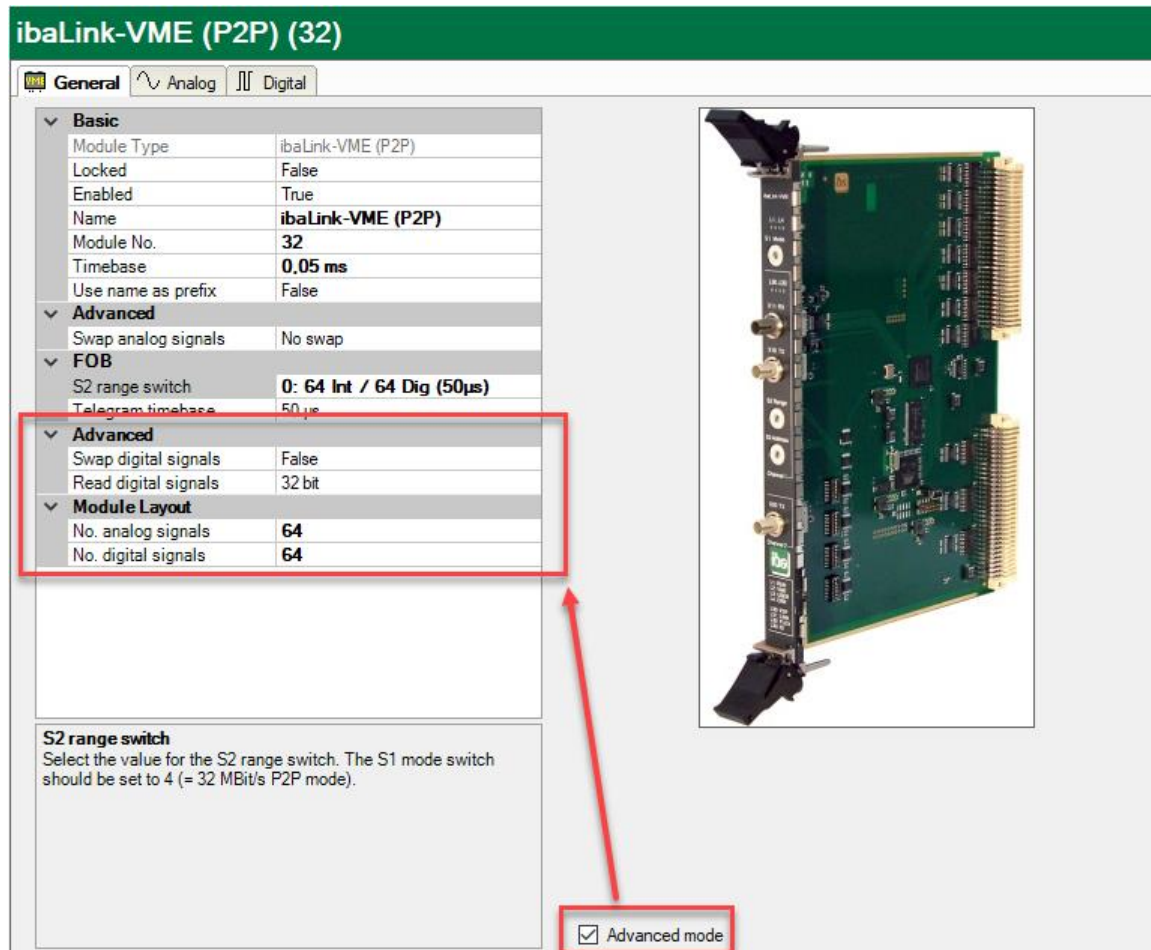

Figure 14 ibaLink-VME (P2P) module, advanced mode

Advanced

Swap digital signals

Digital signals can be inverted (true/false)

Read digital signals

You can choose between 8 bit, 16 bit or 32 bit access to digital signals. Depending on this setting, the bit numbering in the table of the digital signals changes.

No. analog/digital signals

By means of the settings “No. analog signals” and “No. digital signals” you can determine the length of the signal tables. The values should match the setting made under “FOB – S2 range switch” (equal or smaller than).



Note

If **S2 range switch** setting C or D is selected, the advanced mode is automatically activated.

9.1.2.2 Use of the FOB Alarm module

For outputs from ibaPDA to ibaLink-VME, an FO output link and an FO connection to the RX port of ibaLink-VME is necessary. In ibaPDA I/O manager add a module "FOB alarm" at the connected link and specify the desired analog and digital output data.

The FOB Alarm module can be set to Real or Integer mode.

This setting should match the setting of the DP1.3 DIP switch on the ibaLink-VME.

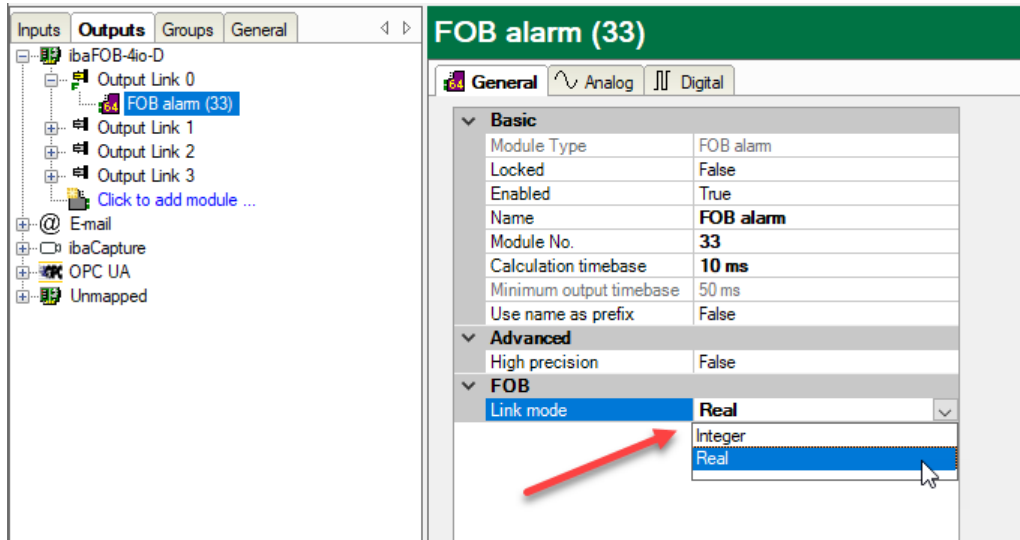

Other documentation

Please refer to the "ibaPDA_Part 2_I/O-Manager" manual, chapter 7.3.17 **FOB alarm output module settings** for more details about the FOB Alarm module.

9.1.3 Configuration in 32Mbit Flex mode

When using 32Mbit Flex mode the number of signals can be adjusted flexibly.

1. Start the ibaPDA client and open the I/O manager
2. Choose the correct ibaFOB-D input card in the signal tree (on the left hand side) and mark the link ibaLink-VME is connected to. Right-click on the link and choose “Autodetect”.

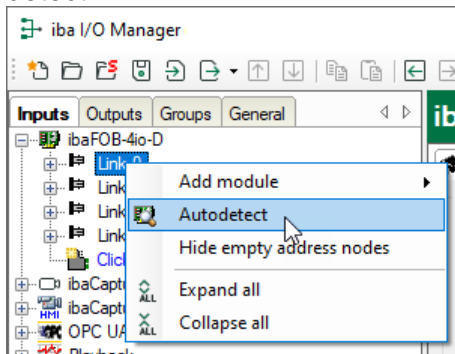

ibaPDA recognizes the device automatically. The device will be listed in the signal tree.

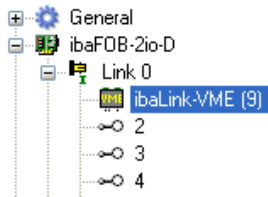

3. Alternatively you can manually add the device. Right-click on the link of the ibaFOB-D card the device should be connected to. Select “Add module...” and then “ibaLink-VME”.

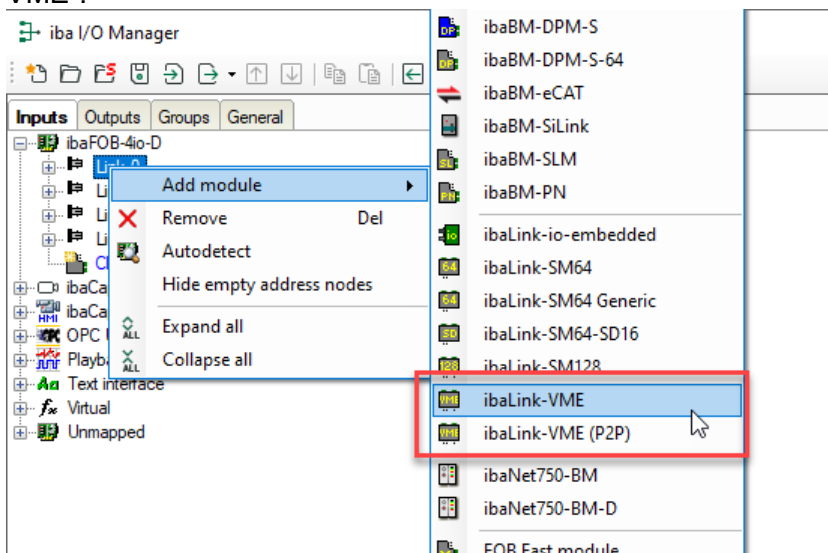

The device will be listed in the signal tree.

4. Hold down the mouse button and drag the device to the address (link 1 – 15 below the device), the device address switch is set to. Position 1 – F refers to address 1 – 15.
5. Make your settings in the ibaLink-VME modules of the I/O Manager:

ibaLink-VME – General tab

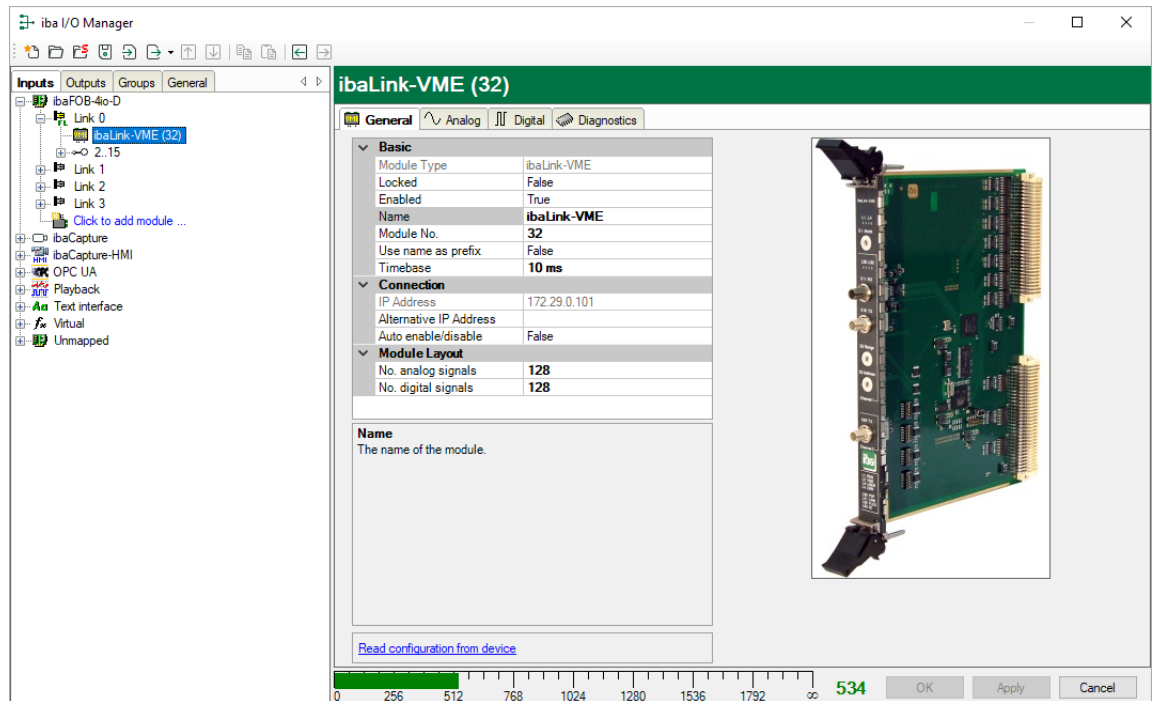

Figure 15: ibaLink-VME – General tab

Basic settings

Locked

A locked module can only be changed by an authorized user.

Enabled

Here, you can activate data capturing for this module (True).

Name

Here, you can enter a module name.

Module No.

Logical module number for clearly referencing the signals, e.g. in expressions and ibaAnalyzer. The ibaPDA gives numbers in chronological order, but the number can be changed by the user.

Timebase

Timebase that is used for the device, given in ms. It is possible to define smaller timebases than defined in the general acquisition timebase. Cycle times down to 25 μ s are possible, depending on the number of signals.

Connection

IP Address

IP address or host name of the device (informative only).

Auto enable/disable

True: ibaPDA starts acquisition, although it cannot connect to the module.

False: ibaPDA won't start acquisition, when it cannot connect to the module.

Module Layout

- No. analog signals

Defining the number of analog signals for this module.

- No. digital signals

Defining the number of digital signals for this module.

Further functions

- Read configuration from device

Reading the configuration from the device.

- Write configuration to device

Writing the configuration to the device.

The changed settings become valid by clicking on <OK> or <Apply>.

ibaLink-VME – Analog tab

Name	Unit	Gain	Offset	Address	DataType	Active	Actual
0		1	0	0x0	FLOAT	<input checked="" type="checkbox"/>	
1		1	0	0x4	FLOAT	<input checked="" type="checkbox"/>	
2		1	0	0x8	FLOAT	<input checked="" type="checkbox"/>	
3		1	0	0xC	FLOAT	<input checked="" type="checkbox"/>	
4		1	0	0x10	FLOAT	<input checked="" type="checkbox"/>	
5		1	0	0x14	FLOAT	<input checked="" type="checkbox"/>	
6		1	0	0x18	FLOAT	<input checked="" type="checkbox"/>	
7		1	0	0x1C	FLOAT	<input checked="" type="checkbox"/>	

Figure 16: ibaLink-VME – Analog tab

Please enter here the analog signals to be recorded sequentially. The columns in the signal list have got the following meaning:

- Name

Assign a meaningful name to each signal and you can enter additionally two comments when clicking on the  symbol in the field "Name".

- Unit

Here, you can enter the physical unit of the analog value.

- Gain / Offset

Gradient (Gain) and y axis intercept (Offset) of a linear equation. You can convert a standardized value transferred without a unit into a physical value.

- Address

The address specifies the Byte offset of the desired signal within the telegram.

Data Type

The data type can be selected from a popup menu:



Note

The address depends on the data type. First select the data type for each signal. When you click on the address field in the title bar, the addresses will be adjusted automatically depending on the size of the used data types.

Active

The signal will be measured when active. Reducing the number of active signals will make it possible to increase the sample frequency (reduce the timebase).

Actual

Displays the actual value of the signal (only available when the measurement is already running with the specified configuration).

ibaLink-VME – Digital tab

ibaLink-VME (32)

General Analog Digital Diagnostics

Name	Address	Bit no.	Active	Actual
0	0x200	0	<input checked="" type="checkbox"/>	
1	0x200	1	<input checked="" type="checkbox"/>	
2	0x200	2	<input checked="" type="checkbox"/>	
3	0x200	3	<input checked="" type="checkbox"/>	
4	0x200	4	<input checked="" type="checkbox"/>	
5	0x200	5	<input checked="" type="checkbox"/>	
6	0x200	6	<input checked="" type="checkbox"/>	
7	0x200	7	<input checked="" type="checkbox"/>	
8	0x201	0	<input checked="" type="checkbox"/>	

Figure 17: ibaLink-VME – Digital tab

Name, Active, Actual

see „Analog“ tab.

Address, Bit no.

The address column and the Bit no. column specify the address of the signal.

ibaLink-VME – Diagnostics tab

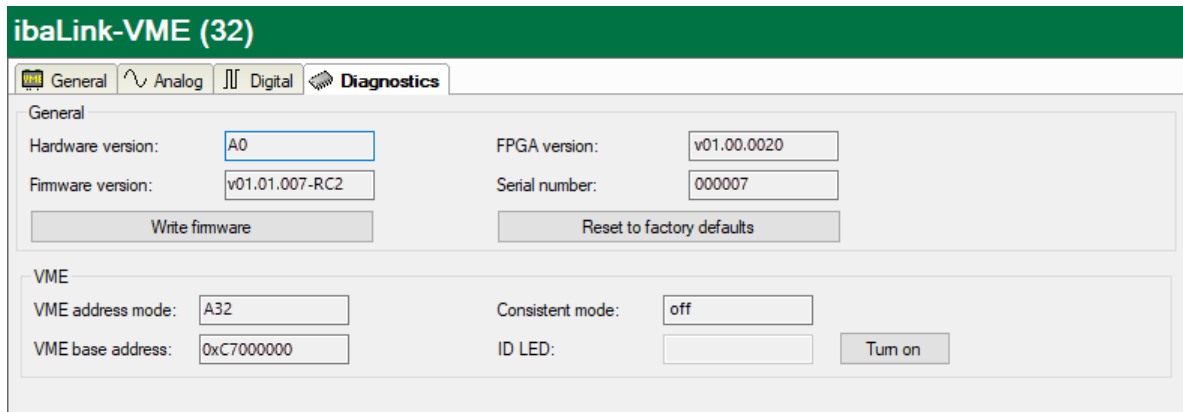

Figure 18: ibaLink-VME – Diagnostics tab

□ General section

The „General“ section gives information about the Hardware version, Firmware version, FPGA version and serial number.

▪ Write firmware

Using this link you can install a firmware update. A click on this link opens a browser window, where you can select the update file. Loading the update takes some minutes. When the update installation is finished, you will be asked to reset the ibaLink-VME module, i.e. the rack the module is plugged in.

▪ Reset to factory defaults

The configuration settings will be deleted.

□ VME section

The “VME” section gives information about the card’s addressing mode and VME base address, as well as if the Coherent Mode DIP switch is enabled. The ID led could be toggled here.

Outputs (alarms)

All modules, you have manually configured at the input side (in the “Inputs” tab) or that are detected automatically, are also displayed at the output side (in the “Outputs” tab). An analog and a digital tab are automatically adjusted for the analog and digital output signals.

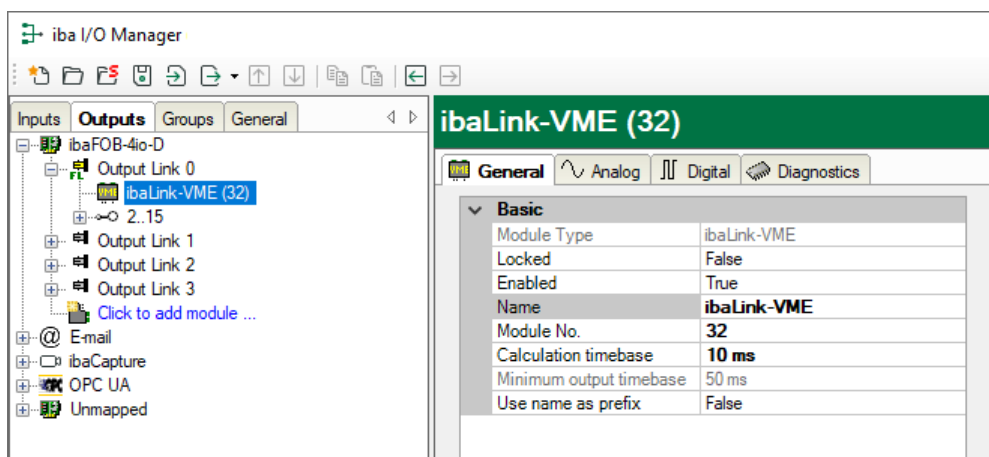

Figure 19: Device in outputs module tree

The digital signals are listed in the digital tab and the analog signals are listed in the analog tab. For each signal you can specify an expression using the expression builder.

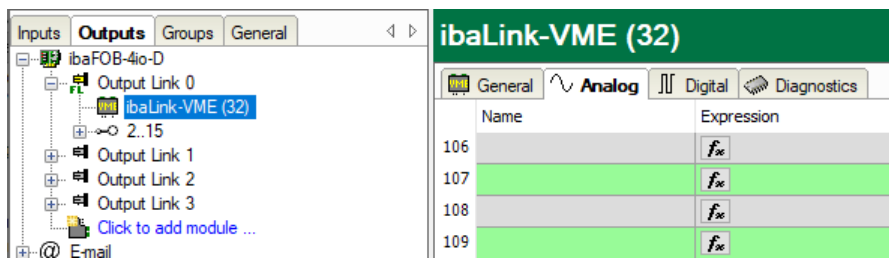

Figure 20: Output signals

9.2 ibaLogic Application

A typical combination of ibaLink-VME and ibaLogic requires connections of the fiber-optic output links to e.g. ibaFOB-2io-D input links. Depending on the ibaLogic version and the used FO card, the following modes can be used.

In order to use the outputs of the ibaLogic application the fiber-optic input link at channel 1 of the ibaLink-VME card must be connected to the output link of an ibaFOB-2io-D card in the ibaLogic-PC.

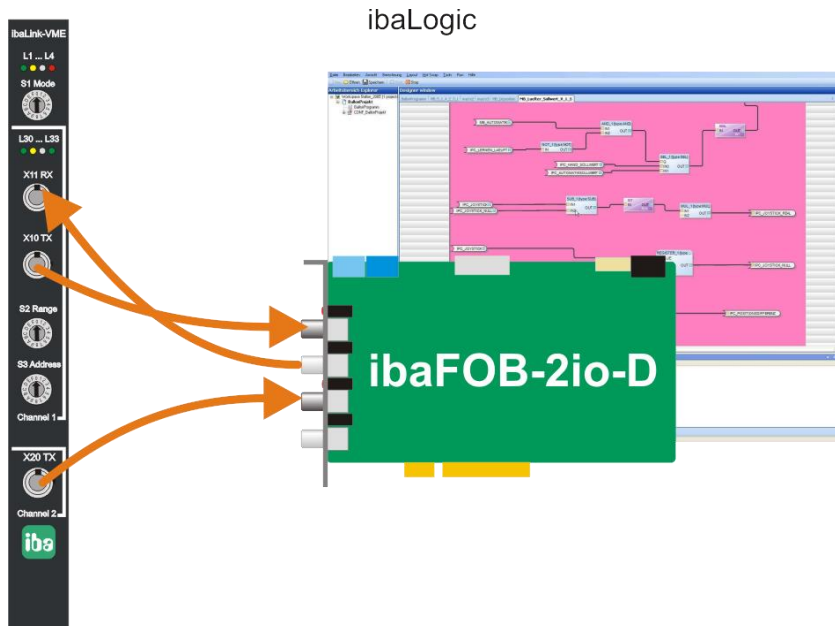

Figure 21: ibaLink-VME with ibaLogic

9.2.1 ibaLogic V3 Configuration

Only the 3Mbit modes (S1 = 0, 1, 8, 9) and the ibaFOB-S or -X cards are supported.



Other documentation

Please refer to the "ibaLink-SM-128V-i-2o" manual.

9.2.2 ibaLogic V4 Configuration

The 3Mbit modes and the 32Mbit P2P mode are supported. In I/O Configurator under the connected link, specify the mode which corresponds to the ibaLink-VME mode. When a bidirectional connection is used, the same mode must be selected for input and output.

Assigning the connection mode in ibaLogic under Windows:

Activate the links under the ibaFOB card

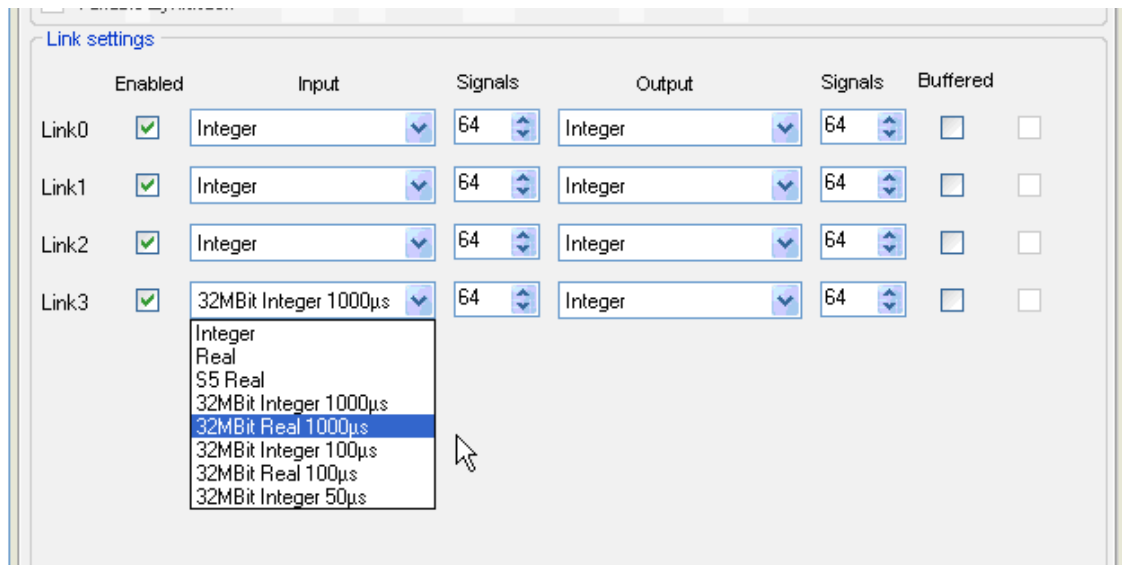

Figure 22: FO link setting under Windows

ibaLogic link mode	ibaLink-VME switch position	Description
Integer	S1 = 8, S2 = x	3Mbit P2P DIP switch DP 1.1/1.3 = OFF
Real	S1 = 8, S2 = x	3Mbit P2P DIP switch DP 1.1/1.3 = ON
S5 Real	-	-
32MBit Integer 1000µs	S1 = 4, S2 = 4	32Mbit P2P (1024 Integer)
32MBit Real 1000µs	S1 = 4, S2 = A	32Mbit P2P (512 Real)
32MBit Integer 100µs	S1 = 4, S2 = 1	32Mbit P2P (128 Integer)
32MBit Real 100µs	S1 = 4, S2 = 7	32Mbit P2P (64 Real)
32MBit Integer 50µs	S1 = 4, S2 = 0	32Mbit P2P (64 Integer)

Table 5: ibaLogic (WIN) link mode settings

Assigning the connection mode in ibaLogic under ibaPADU-S-IT:

Use the input and output resources "FiberOptics_IO".

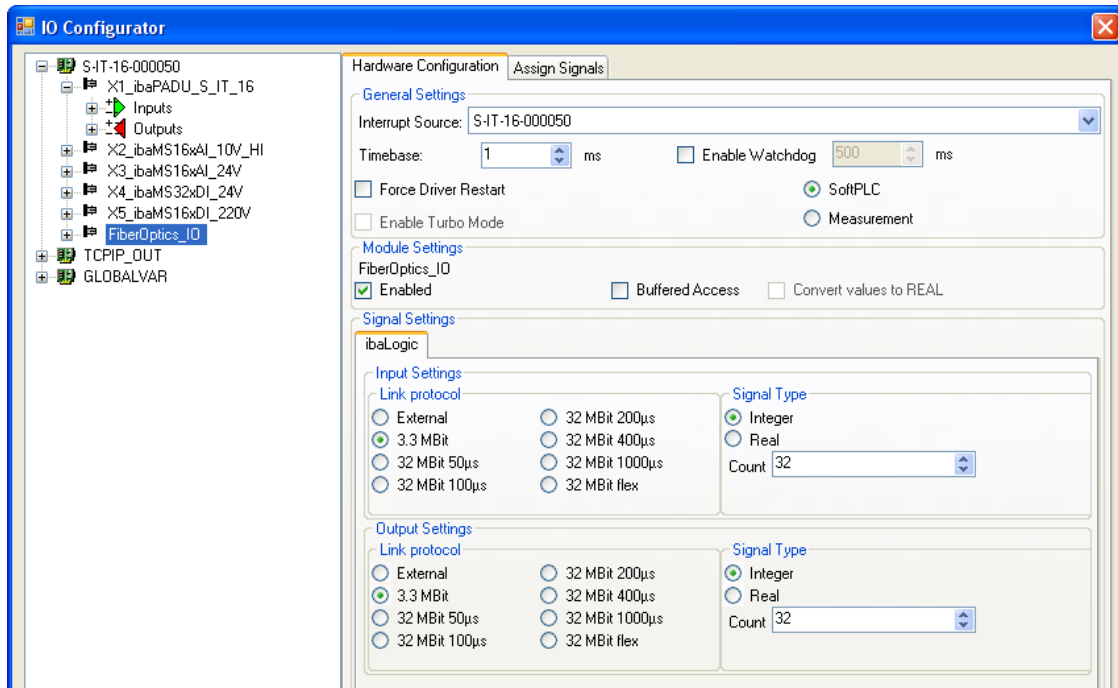

Figure 23: FO link setting under ibaPADU-S-IT

ibaLogic link protocol	Signal type	ibaLink-VME switch position	Description
External		-	-
3.3 MBit	Integer	S1 = 8, S2 = x	DIP switch DP1.1/1.3 according to the signal type
	Real	S1 = 8, S2 = x	
32 MBit 50µs	Integer	S1 = 4, S2 = 0	32Mbit P2P (64 Integer)
	Real	S1 = 4, S2 = 7	32Mbit P2P (64 Real)
32 MBit 100µs	Integer	S1 = 4, S2 = 2	32Mbit P2P (256 Integer)
	Real	S1 = 4, S2 = 8	32Mbit P2P (128 Real)
32 MBit 200µs	Integer	S1 = 4, S2 = 3	32Mbit P2P (512 Integer)
	Real	S1 = 4, S2 = 9	32Mbit P2P (256 Real)
32 MBit 400µs	Integer	S1 = 4, S2 = 4	32Mbit P2P (1024 Integer)
	Real	S1 = 4, S2 = A	32Mbit P2P (512 Real)

Table 6: ibaLogic (PADU-S-IT) link mode settings

9.3 Cascade with 3Mbit mode

Up to eight cascadable devices may be cascaded in a single daisy-chain of fiber-optic devices (Channel 1 only). Cascadable devices are: ibaLink-VME, ibaLink-SM128V, ibaPADU-8/-16/-32 and ibaNet750, but not ibaLink-SM-64, because its cascading concept is different.

The total of 64 a/d signals to be transmitted over one fiber-optic link is subdivided into eight slots of eight a/d signals each. The slots are divided between several participants in a cascade.

In this mode, each ibaLink-VME participating in the chain is forwarding the 8 incoming data slots on its fiber optic input towards its fiber optic output, only replacing one or more successive slots (S2 Range switch) by the data provided in the VME transmit buffer. The first slot to be replaced is configured using the S3 Address switch.

Independent from the S2/S3 switches, the data of the 8 incoming slots is always available in the VME receive buffer.

The setting of S1 switch is 0 (zero) or 1 in cascade mode.

Example 1: System Topology for Daisy-Chain of 8 ibaLink-VME with equal ranges

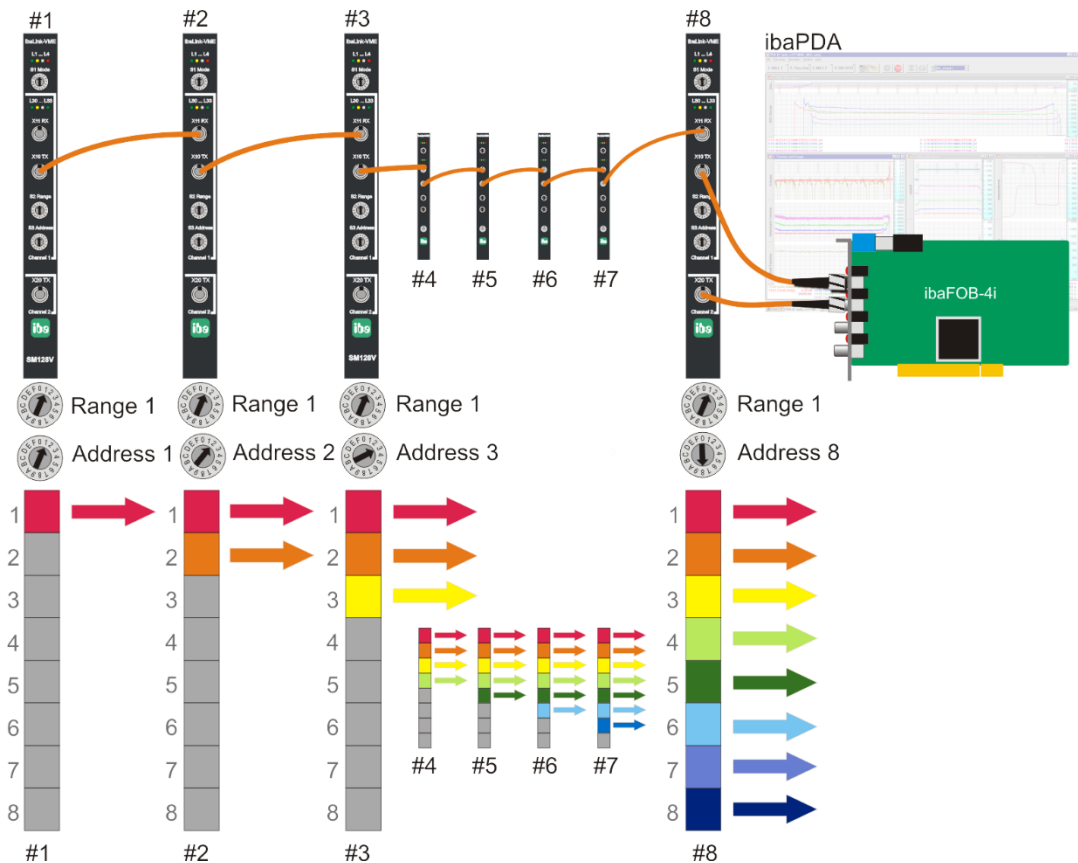

Figure 24 Cascade mode with 8 x ibaLink-VME

Eight ibaLink-VME interface cards are daisy-chained with each card transmitting 8 signals for the resulting daisy-chain telegram. The address switch position determines the slot to be occupied. After the last ibaLink-VME card all slots are filled with data. The FO input of the ibaFOB card receives 8 x 8 = 64 signals.

The second link of the card (Channel 2) may be used for independent transmission of up to 64 a/d signals.

Example 2: System Topology for Daisy-Chain of 3 ibaLink-VME with different ranges

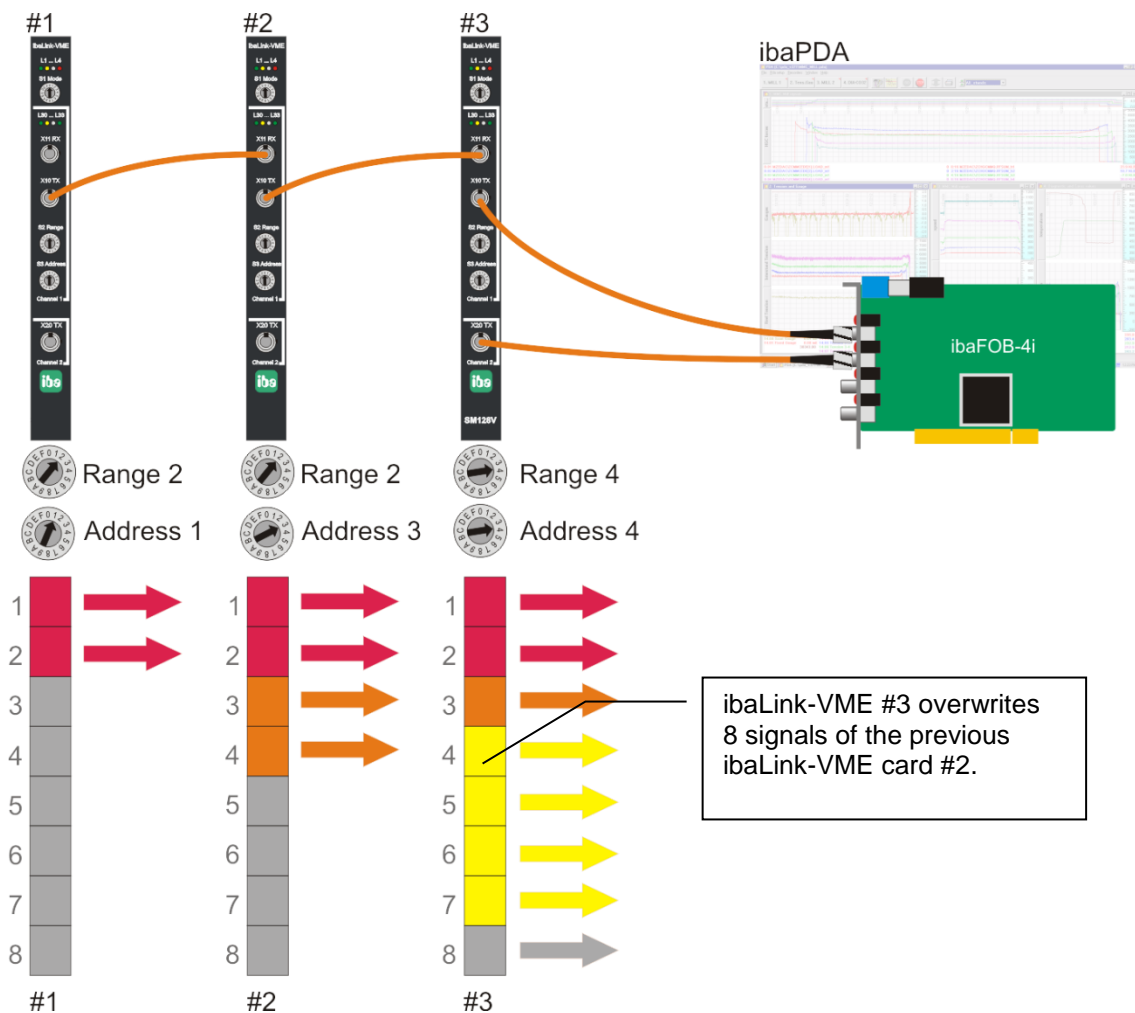

Figure 25 Cascade mode with 3 x ibaLink-VME

Three ibaLink-VME interface cards are daisy-chained, transmitting different amounts of data.

Card #1 transmits 2 containers and occupies the first two slots; card #2 transmits 2 containers and occupies the next two slots; card #3 transmits 4 containers, but the address switch is set to 4. So a slot, already filled with data from card #2, is overwritten. Since the last participant in a daisy-chain is dominant, a container of card #2 gets lost. In order to avoid this, the address switch of card #3 should point on 5.



Flow of Data Considerations

Be careful to note that the data is written to each ibaLink-VME local dual port RAM. Consider the example above, card #2 receives 16 signals from card #1, card #3 receives 16 signals from card #1 and 16 signals from card #2.

When two ranges overlap each other, the 2 x 8 signals will get to the DPR of card #3, but card #3 overwrites the last signals of card #2 with own signals. So only 8 signals of card #2 reach the FOB card, although the signals are transferred from card #2 to card #3.



Note

We recommend that the sequence in the cascade (predecessor → successor) is according to the ascending address order, although this is not mandatory.

In case of overlapping ranges the successors overwrite the data of the predecessors, independent from the addresses.

9.4 Cascade with 32Mbit Flex

Up to 15 ibaLink-VME cards or other iba devices, which support 32Mbit Flex mode, can be cascaded in a FO ring (only channel 1).

Switch S3 (Address) specifies a unique device address 1...F, which corresponds to an address 1..15.

Example:

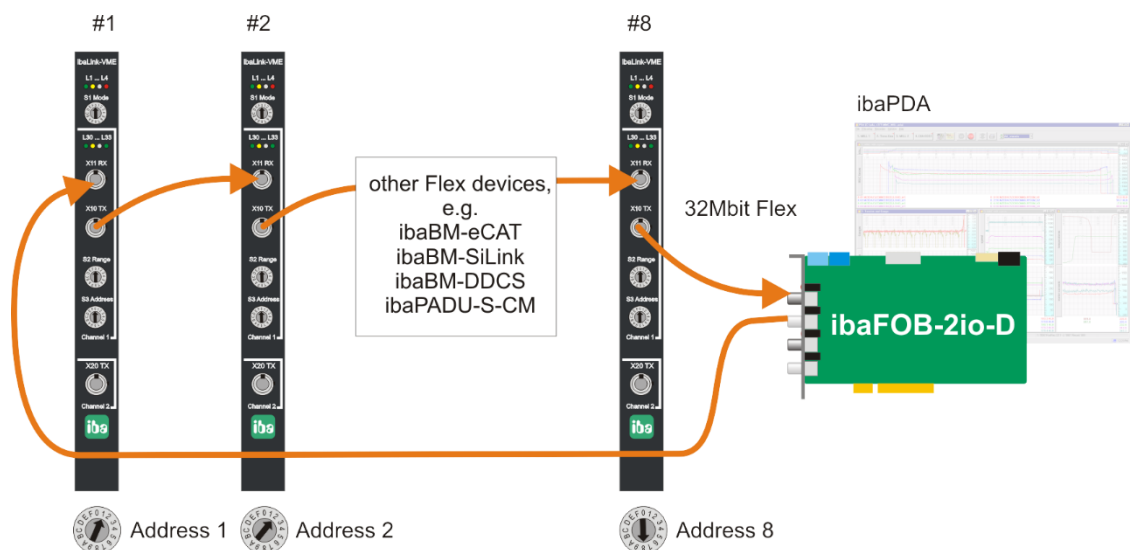

Figure 26 Cascading with Flex devices

The amount of data per participant is not defined by switches like in 3Mbit mode, but is allocated dynamically. According to the number of analog and digital signals configured in ibaPDA and the configured timebase the amount of data is calculated by ibaPDA.

The maximum total data rate is determined by the fiber-optic links and must be divided through the number of devices and the amount of data per device. A reference value is approx. 3000 bytes per ms.

The devices can work with different cycle times, however the cycle time must be an integer multiple of the smallest cycle.

If the maximum data rate is exceeded, ibaPDA displays an error message and recommends increasing the timebase or decreasing the amount of data.

9.5 Process I/O Mode

ibaLink-VME can serve as a process i/o bus extender for PLC systems.

ibaPADU-8-O can be used as an output device, ibaPADU-8 devices as inputs. Up to 8 devices can be connected to channel 1 (each input and output), up to 8 output devices can be connected to channel 2.

Components of the ibaNet750-BM series (WAGO / Beckhoff) can also be used as input and output devices. ibaPDA and ibaLogic can also be connected.

Only line structures are allowed at the fiber-optic links.

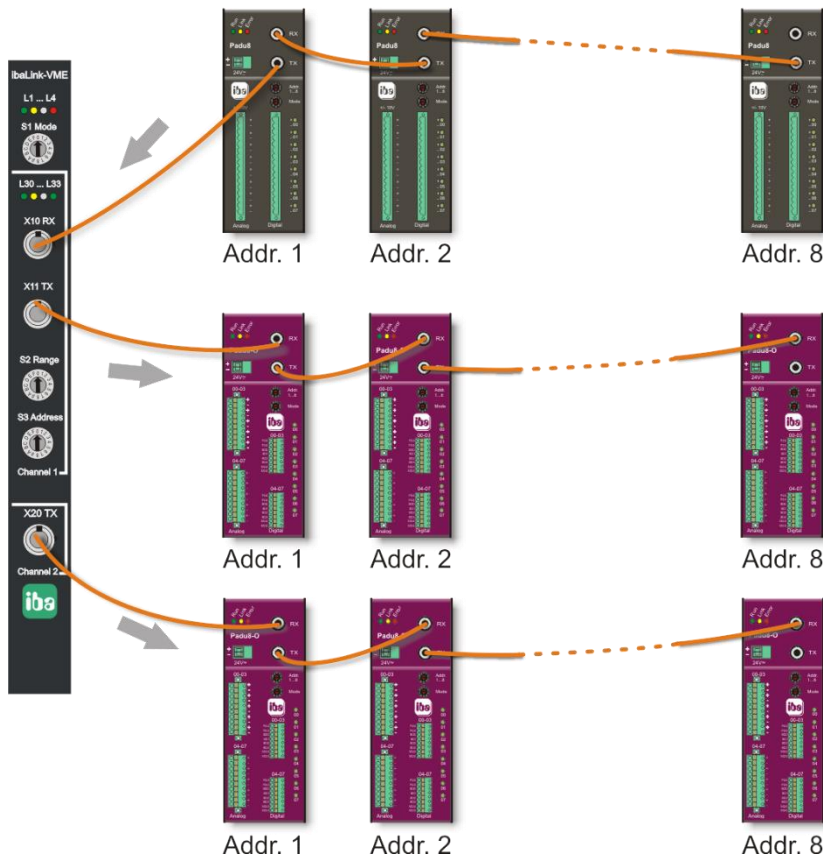

Figure 27 System topology for process i/o application with ibaPADU-8 and ibaPADU-8-O

A combination of cascade mode and I/O mode at one card is possible. For example, channel 1 could connect a cascade and channel 2 could be used as output.

10 The VMEbus interface

The card occupies 256 kByte memory space on the VMEbus. The VME base address and addressing mode is adjustable using the DIP switch settings as described above.

From the VMEbus viewpoint, Words and Dwords can be read and written in Big Endian or Little Endian format. The ibaLink-VME card can accept both formats. The used format has to be configured with a DIP switch.

Whether the link sends in integer or float format must be defined prior to installing the ibaLink-VME. Use the DIP switch to change this setting for each fiber optic link. Each fiber-optic link can be set independently.



Note

When 32Mbit Flex is used, all data format settings are configured with ibaPDA, not with DIP switches.

For 3Mbit modes the digital channel values may be written word-wise (1 DWORD for each digital signal (bit 0 of each DWORD)) or all packed in an 8 byte bit mask. Prior to sending the telegram the respective registers are OR'd to determine whether a 0 or 1 is sent in the telegram. For this reason, it is important to reset the registers of the unused method.



Note

The ibaLink-VME is initialized (transmit buffers zeroed) on power reset and VME bus SYSRESET and ready for use. It may, but must not, be reset using the hardware reset control register.

After a firmware update a power cycle is required in order for the new firmware to take effect.

10.1 Address mapping

The address space as seen from the VMEbus has a size of 256KB [A17...A0]. It is mapped to the absolute address specified with the DIP switches (A39...A18). The meaning and use of the DIP switches depends on the VME addressing mode:

A16 mode: Not supported

A24 mode: DIP switches [A23...A18] are used

A32 mode: DIP switches [A31...A18] are used

A40 mode: DIP switches [A39...A18] are used

A64 mode: DIP switches [A39...A18] are used, specifying A[63:42], A[41:18]=0

10.2 Global overview

The address space is compatible with the SM128. Reserved areas return zero on reads. Writing to reserved areas has no effect.

Global overview of the 256K address space:

Offset Range	Use
0x0000-0x00FF	Control/Status/Version Registers
0x0100-0x0FFF	Reserved
0x1000-0x3FFF	SM128 Receive/Transmit data (3Mbit)
0x4000-0x4FFF	Reserved
0x5000-0x5F37	3896 byte buffer mirrored to 0xC000-0xCF37 (part of 4K Transmit buffer)
0x5F38-0x5FFF	Reserved
0x6000-0x607F	128 byte buffer mirrored to 0xCF38-0xCFB7 (part of 4K Transmit buffer)
0x6080-0x6FFF	Reserved
0x7000-0x7FFF	4K Transmit buffer digital output DWORD (32Mbit)
0x8000-0x8FFF	4K Receive buffer (32Mbit P2P and Flex)
0x9000-0xBFFF	Reserved
0xC000-0xCFFF	4K Transmit buffer (32Mbit P2P and Flex)
0xD000-0x3FFFF	Reserved

10.3 Control/Status/Version registers

Offsets which are not mentioned are reserved (do not write to them). Except where mentioned, registers are read-only.

For SM128 compatible modes, the version registers contain SM128 identification strings in order to maximize compatibility with the real SM128 boards.

Offset	Format	Meaning
0x08	byte	Write 0x5A for board reset (memories are zeroed)
0x60	12 bytes	Firmware description "SM128-VME____" (SM128) Firmware description "ibaLink-VME_" (Flex,...)
0x6C	4 bytes	Firmware revision level "F1.5" (SM128) Firmware revision level "F2.0" or other (Flex,...)
0xE4	byte	Led indicators (1=LedOn 0=LedOff) Only bit 4 is writeable Bit4=Software Controlled Led (white)
0xE8	byte	Bit0 : 0=Coherent Mode Disabled 1=Coherent Mode Enabled (reflects the status of the DIP switch) Bit5 : write 1 to Get RX1 buffer Bit7 : write 1 to Commit TX1 & TX2 buffer
0xF0	byte	FO Mode = 01: 3Mbit = 03: 32Mbit P2P = 0B: 32Mbit Flex

10.4 SM128 RX/TX

Remark: byte: format not influenced by the Endianess DIP switch

Dword: format depending on the Endianess DIP switch

Offset	Format	Meaning
0x1801	byte	Fiber Optic Input Status & DIP Status Channel 1 Bit0: 0=link down 1=link ok (receiving telegrams) Bit6: 0=RX Data to be saved in Little Endian format 1=RX Data to be saved in Big Endian format (reflects the status of the DIP switch) Bit7: 0=RX Data to be saved in 16bit Integer format 1=RX Data to be saved in 32bit IEEE float (Real) format (reflects the status of the DIP switch)
0x1803	byte	Fiber Optic Output Status & DIP Status Channel 1 Bit6: 0=TX1 Data was written in Little Endian format 1=TX1 Data was written in Big Endian format (reflects the status of the DIP switch) Bit7: 0=TX1 Data was written in 16bit Integer format 1=TX1 Data was written in 32bit IEEE float (Real) format (reflects the status of the DIP switch)
0x1A03	byte	Fiber Optic Output Status & DIP Status Channel 2 Bit6: 0=TX2 Data was written in Little Endian format 1=TX2 Data was written in Big Endian format (reflects the status of the DIP switch) Bit7: 0=TX2 Data was written in 16bit Integer format 1=TX2 Data was written in 32bit IEEE float (Real) format (reflects the status of the DIP switch)
0x2400... 0x2407	8 bytes	Channel 1 - 64 digital inputs, bitwise packed into 8 bytes. First signal is in the lsb.
0x2420... 0x2427	8 bytes	Channel 1 - 64 digital outputs, bitwise packed into 8 bytes. First signal is in the lsb. The actual output is OR'ed with the lsb of the corresponding DWORD in region 0x3E00.
0x2428... 0x242F	8 bytes	Channel 2 - 64 digital outputs, bitwise packed into 8 bytes. First signal is in the lsb. The actual output is OR'ed with the lsb of the corresponding DWORD in region 0x3F00.
0x3000... 0x30FF	64 dwords	Channel 1 - 64 analog inputs, each input reserves 1 DWORD. Most significant 2 bytes are set to zero when in integer mode.
0x3800... 0x38FF	64 dwords	Channel 1 - 64 analog outputs, each output reserves 1 DWORD. Most significant 2 bytes are not used when in integer mode
0x3900... 0x39FF	64 dwords	Channel 2 - 64 analog outputs, each output reserves 1 DWORD. Most significant 2 bytes are not used when in integer mode.
0x3E00... 0x3EFF	64 dwords	Channel 1 - 64 digital outputs, each signal reserves 1 DWORD, only the lsb of each DWORD is used. The actual output is OR'ed with the corresponding bit in region 0x2420.
0x3F00... 0x3FFF	64 dwords	Channel 2 - 64 digital outputs, each signal reserves 1 DWORD, only the lsb of each DWORD is used. The actual output is OR'ed with the corresponding bit in region 0x2428.

Coherent Mode

When Coherent Mode is enabled, the output data is only sent to the fiber optic output after setting the TX1/TX2 Commit bit in the Control Register 0xE8. Committing the TX buffers should not happen faster than 10 µs!

When Coherent Mode is enabled, the input data is only updated to the last received data after setting the RX1 Get bit in the Control Register 0xE8.

10.5 4K RX/TX buffers

These buffers are used to receive and transmit data for the 32Mbit Flex and 32Mbit P2P Modes.

The buffers are 4K in size each. The format of these buffers depends on the mode.

10.5.1 32Mbit P2P

Within this mode there are 2 formats used: the free format where the data is considered as a sequence of bytes (Range switch set to C or D) and the other standard 32Mbit modes where the data is divided into analog (Integers or Reals) and digital bits.

- Free format: up to the first 4024 bytes of the buffer are received/transmitted as is
- Standard format: up to the first 2048 bytes are used to receive/transmit the analog values. The endianness is according to the DIP switch setting. Starting at offset 3968 (0xF80) the digital bits are located (packed together in bytes).
Alternatively, binary data can be sent in "DWORD" format starting at offset 0x7000. A DWORD is sent per bit with LSB = true/false. These binary data are **not** logically linked by an OR function with the packed binary outputs (0xCF80).

10.5.2 32Mbit Flex

In 32Mbit Flex mode the complete 4K transmit buffer is available to store transmit data. However, only a maximum of 4060 bytes could be selected for transmission on the fiber optic. On the receive side a block of maximum 4060 bytes can be received.

The format of the data (endianness, bytes, reals, etc) should be configured in ibaPDA. The endianness and REAL/INT DIP switches are not used in 32Mbit Flex mode.

11 Technical Data

11.1 Main data

Manufacturer	iba AG, Germany	
Order no.	ibaLink-VME: 14.132000 ibaLink-VME-16Bit: 14.132001 (on request)	
Communication channels	Channel 1: In-/Output Channel 2: Output	
ibaNet protocols	3Mbit, 32Mbit, 32Mbit Flex	
Connector type	2 ST connectors for RX and TX; iba recommends the use of FO with multimode fibers of type 50/125 µm or 62.5/125 µm; For information on cable length, see chap. 11.3	
Transmitting interface (TX)		
Output power	50/125 µm FO cable	-19.8 dBm to -12.8 dBm
	62.5/125 µm FO cable	-16 dBm to -9 dBm
	100/140 µm FO cable	-12,5 dBm to -5.5 dBm
	200 µm FO cable	-8.5 dBm to -1.5 dBm
Temperature range	-40 °F to 185 °F (-40 °C to 85 °C)	
Light wavelength	850 nm	
Receiving interface (RX)		
Sensitivity ¹	100/140 µm FO cable	-33.2 dBm to -26.7 dBm
	Temperature range	-40 °F to 185 °F (-40 °C to 85 °C)
Galvanic isolation	via FO	
Power supply:	5 V from VMEbus	
Current consumption:	Maximum 1 A / 5 V	
Indicators	8 LEDs for operating status	
Humidity:	Class F condensation not allowed	
Cooling:	Natural convection	
Installation:	1 slot in standard VME chassis (6 U)	
Operating temperature:	0 °C to 50 °C (32 °F...122 °F)	
Storage temperature:	-25 °C to 70 °C (-13 °F...158 °F)	
Transport temperature:	-25 °C to 70 °C (-13 °F...158 °F)	
Dimensions in mm (WxHxD) in inches	1 VME Slot x 233 mm x 160 mm 1 VME Slot x 9.2 " x 6.3 "	
Front panel	6 U / 4 HP	
Weight (incl. package/documents)	approx. 1.1 lbs (0.5 kg)	

¹ Data for other FO cable diameters not specified

**Supplier's Declaration of Conformity
47 CFR § 2.1077 Compliance Information**

Unique Identifier: 14.132000 ibaLink-VME

Responsible Party - U.S. Contact Information
 iba America, LLC
 370 Winkler Drive, Suite C
 Alpharetta, Georgia
 30004

(770) 886-2318-102
www.iba-america.com

FCC Compliance Statement
 This device complies with Part 15 of the FCC Rules. Operation is subject to the following two conditions: (1) This device may not cause harmful interference, and (2) this device must accept any interference received, including interference that may cause undesired operation.

11.2 Dimension sheet

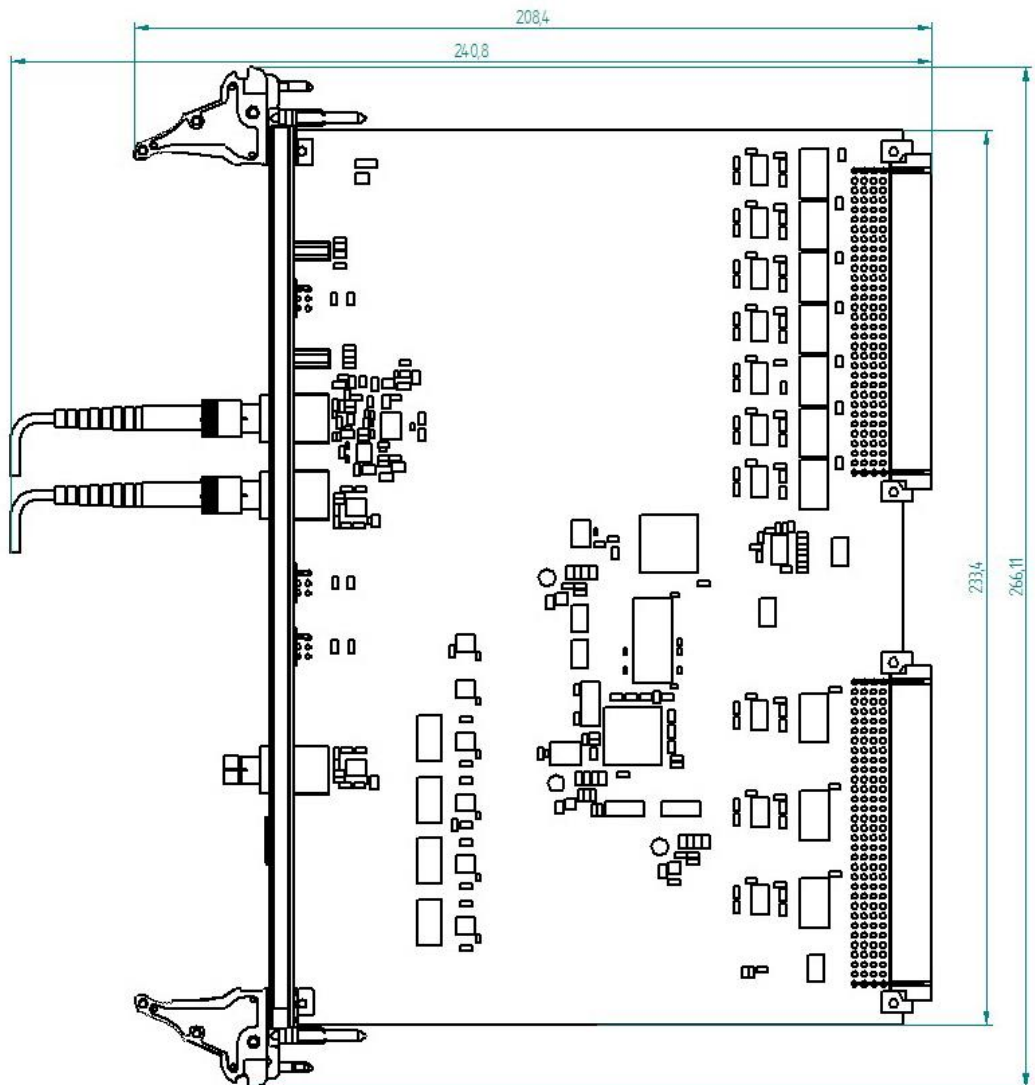

Figure 28: Dimension sheet (dimensions in mm)

11.3 Example for FO budget calculation

As an example, an FO connection from an ibaFOB-io-Dexp card (FO transmitter) to an ibaBM-PN device (FO receiver) is used.

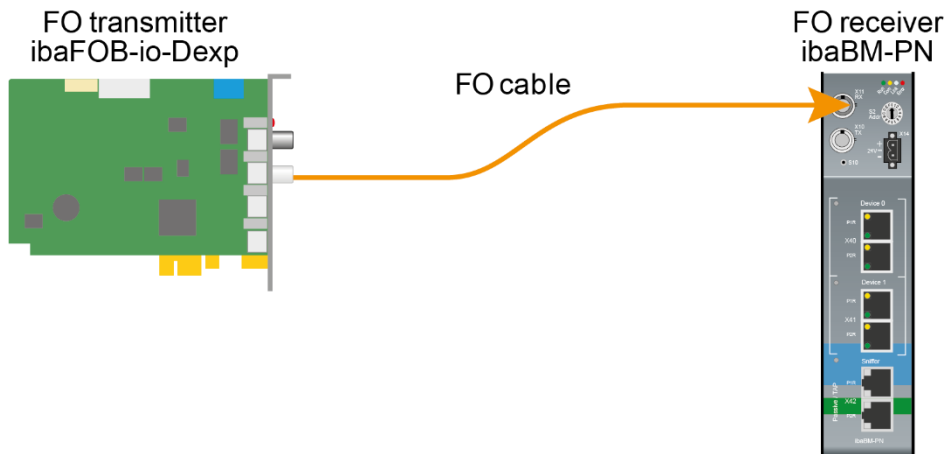

Figure 1: Example: simple connection for FO budget calculation

The example refers to a point-to-point connection with an FO cable of type 62.5/125 μm . The light wavelength used is 850 nm.

The range of the minimum and maximum values of the output power or receiver sensitivity depends on the component and, among other things, on temperature and aging.

For the calculation, the specified output power of the transmitting device and on the other side the specified sensitivity of the receiving device must be used in each case. You will find the corresponding values in the respective device manual in the chapter "Technical data" under "ibaNet interface".

Specification ibaFOB-io-Dexp:

Output power of FO transmitting interface		
FO cable in μm	Min.	Max.
62.5/125	-16 dBm	-9 dBm

Specification ibaBM-PN:

Sensitivity of FO receiving interface		
FO cable in μm	Min.	Max.
62.5/125	-30 dBm	

Specification FO cable

To be found in the data sheet of the fiber optic cable used:

FO cable	62.5/125 μm
Connector loss	0.5 dB connector
Cable attenuation at 850 nm wavelength	3.5 dB / km

Equation for calculating the FO budget (A_{Budget}):

$$A_{Budget} = |(P_{Receiver} - P_{Sender})|$$

$P_{Receiver}$ = sensitivity of FO receiving interface

P_{Sender} = output power of FO transmitting interface

Equation for calculating the fiber optic cable length (l_{Max}):

$$l_{Max} = \frac{A_{Budget} - (2 \cdot A_{Connector})}{A_{Fiberoptic}}$$

$A_{Connector}$ = connector loss

$A_{Fiberoptic}$ = cable attenuation

Calculation for the example ibaFOB-io-Dexp -> ibaBM-PN in the best case:

$$A_{Budget} = |(-30 \text{ dBm} - (-9 \text{ dBm}))| = 21 \text{ dB}$$

$$l_{Max} = \frac{21 \text{ dB} - (2 \cdot 0.5 \text{ dB})}{3.5 \frac{\text{dB}}{\text{km}}} = 5.71 \text{ km}$$

Calculation for the example ibaFOB-io-Dexp -> ibaBM-PN in the worst case:

$$A_{Budget} = |-30 \text{ dBm} - (-16 \text{ dBm})| = 14 \text{ dB}$$

$$l_{Max} = \frac{14 \text{ dB} - (2 \cdot 0.5 \text{ dB})}{3.5 \frac{\text{dB}}{\text{km}}} = 3.71 \text{ km}$$

**Note**

When connecting several devices as daisy chain (e.g. ibaPADU-8x with 3Mbit) or as ring (e.g. ibaPADU-S-CM with 32Mbit Flex), the maximum distance applies to the section between two devices. The FO signals are re-amplified in each device.

**Note**

When using fiber optics of the 50/125 μm type, a distance reduction of approx. 30-40% must be expected.

12 Support and contact

Support

Phone: +49 911 97282-14

Fax: +49 911 97282-33

E-Mail: support@iba-ag.com



Note

If you require support, specify the serial number (iba-S/N) of the product.

Contact

Headquarters

iba AG

Koenigswarterstrasse 44

D-90762 Fuerth

Germany

Phone.: +49 911 97282-0

Fax: +49 911 97282-33

E-mail: iba@iba-ag.com

Mailing address

iba AG

Postbox 1828

D-90708 Fuerth

Germany

Delivery address

iba AG

Gebhardtstrasse 10

D-90762 Fuerth

Germany

Regional and Worldwide

For contact data of your regional iba office or representative please refer to our web site

www.iba-ag.com.